

10360 - GALLINERO - 1,5X1,8 Mt.

10361 - KIT DESPLAZAMIENTO PARA GALLINERO - 1,5X1,8 Mt.

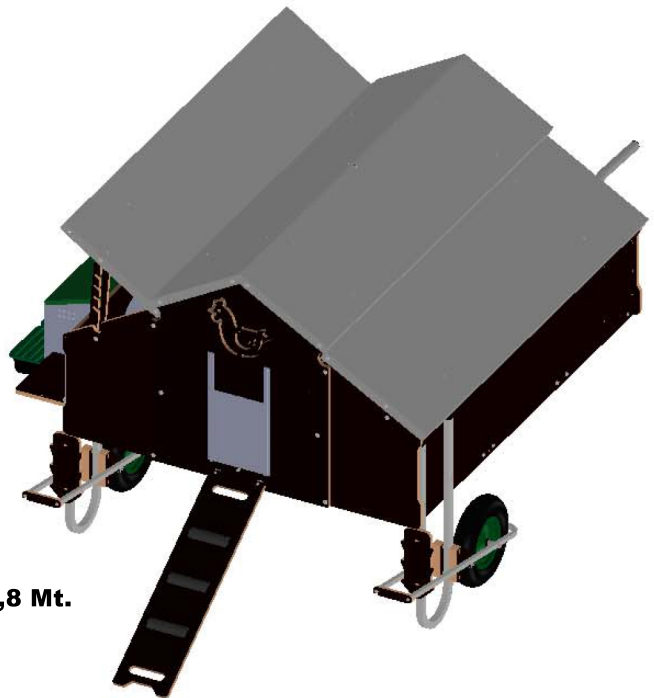

10340 - GALLINERO MÓVIL - 1,5X1,8 Mt.

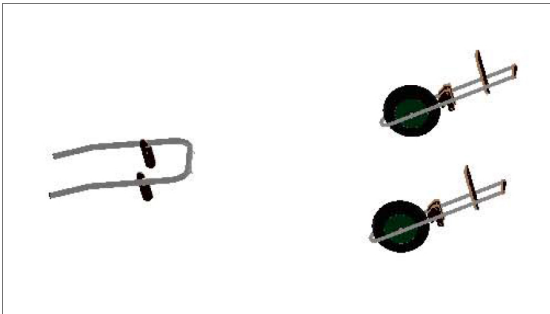
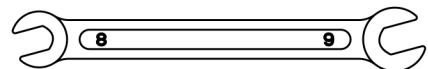

8 - 9
10 - 11
12 - 13

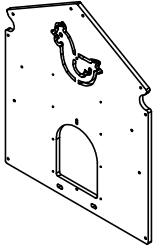

A x1

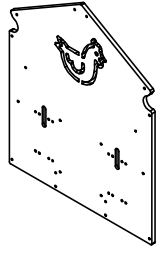

B x1

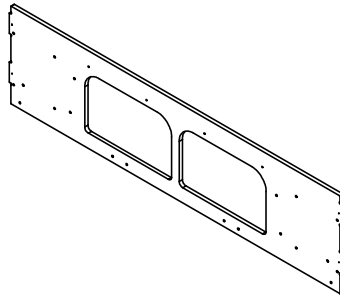

C x1

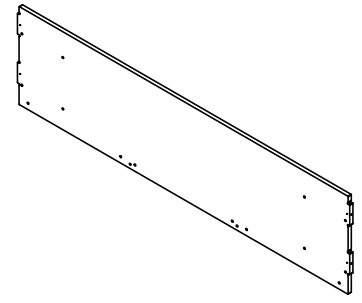

D x1

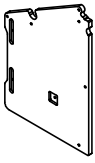

E x1

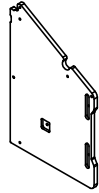

F x1

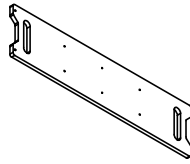

G x1

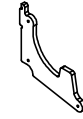

H x2



I x1

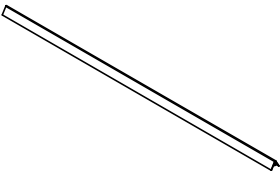

J x6

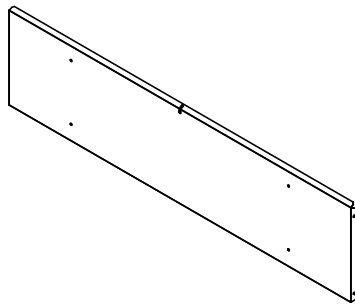

K x2

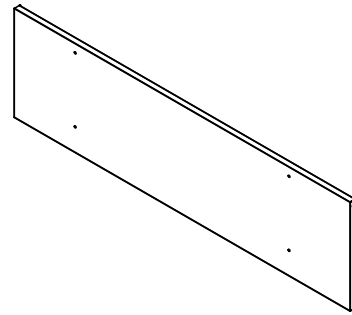

L x2

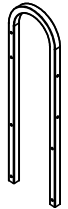

M x3

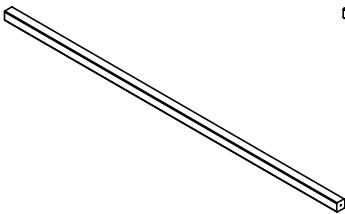

N x2
1864 mm

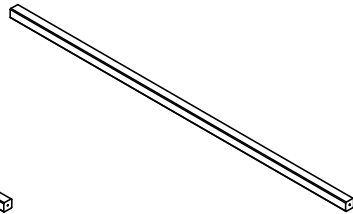

O x2
1882 mm

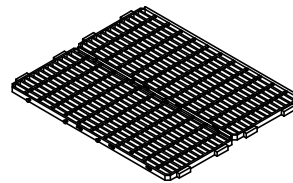

P x9



Q x4

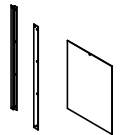

R x1



S x4



T x2



U x3



V x1



A2 x1

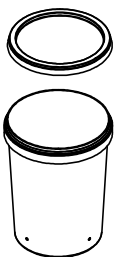

W x1

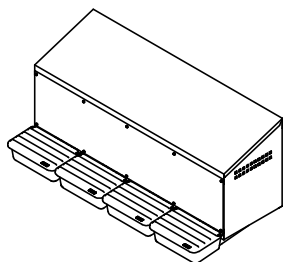

X x1



Y x1



Z x1



A1 x1

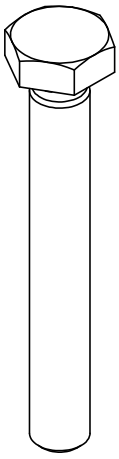

DIN 933 M8x60
x12

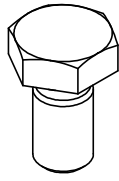

DIN 933 M8x15
x2

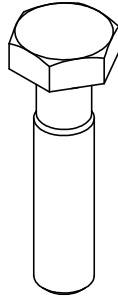

DIN 933 M8x30
x15

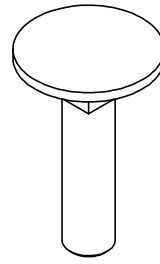

DIN 603 M8x30
x30

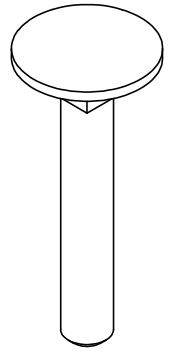

DIN 603 M8x45
x20

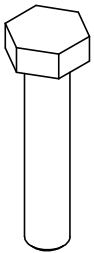

DIN 933 M6x30
x8

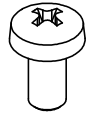

DIN 7985 M5x10
x18

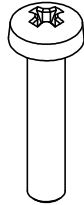

DIN 7985 M5x30
x6

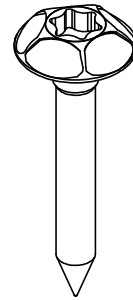

TORX \varnothing 6x40
x16

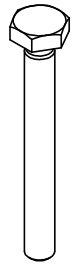

DIN 933 M4x35
x1

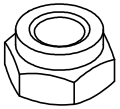

DIN 985 M8
autoblock x14

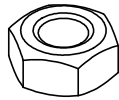

DIN 934 M8
x37



DIN 934 M6
x26



DIN 934 M5
x6

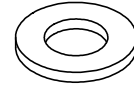

DIN 125 M8
x65

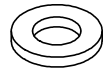

DIN 125 M6
x26



DIN M5
x6

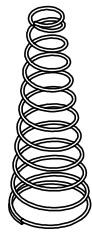

B1 x1

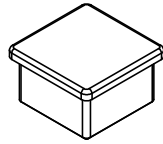

B2 x6

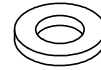

DIN 9021 M5
x18

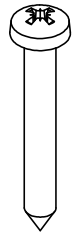

Tornillo autorroscante 4,2x32
x6

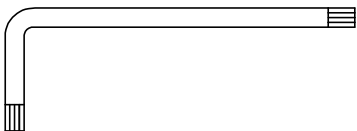

Torx Tx40

PASO 1

DIN 7985 M5x30 (x8)
DIN 125 (x8)
DIN 934 (x8)

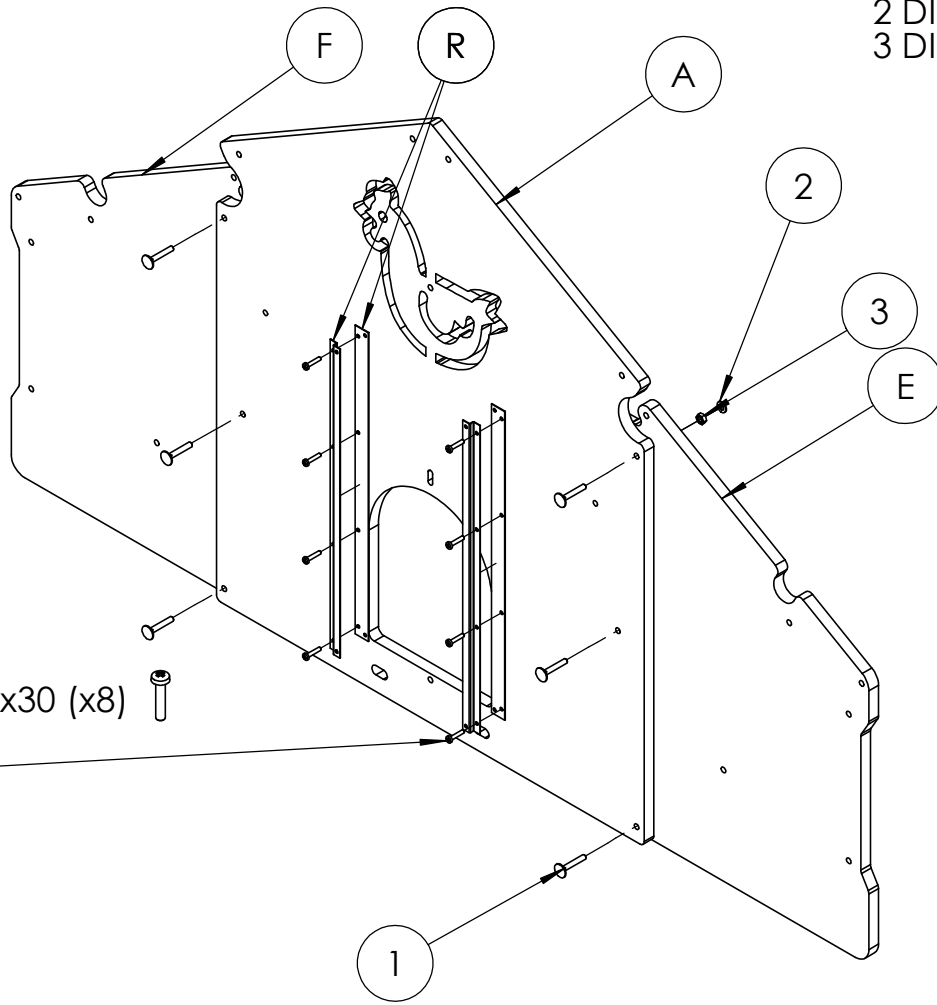

1 DIN 603 M8x45 (x6)
2 DIN 125 M8 (x6)
3 DIN 934 M8 (x6)



PASO 2

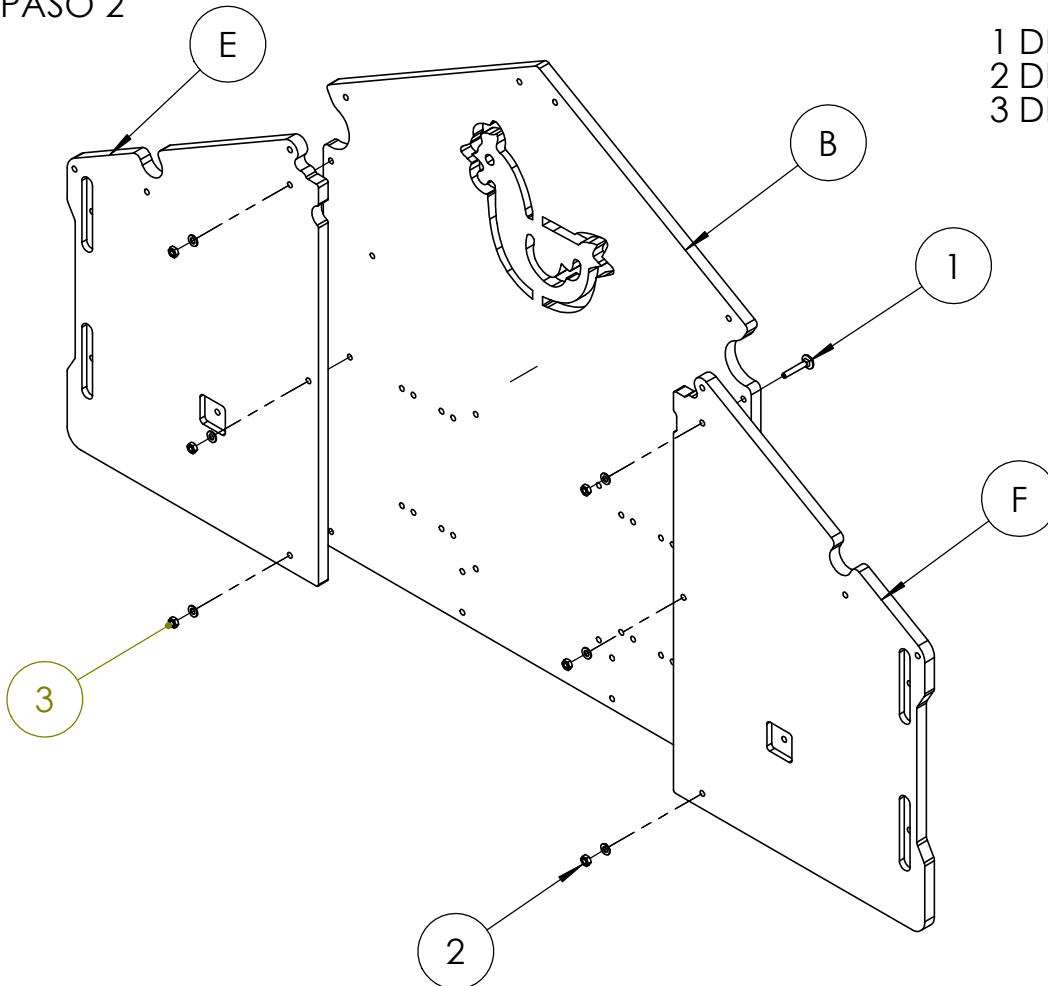

1 DIN 603 M8x45 (x6)
2 DIN 125 M8 (x6)
3 DIN 934 M8 (x6)



PASO 3

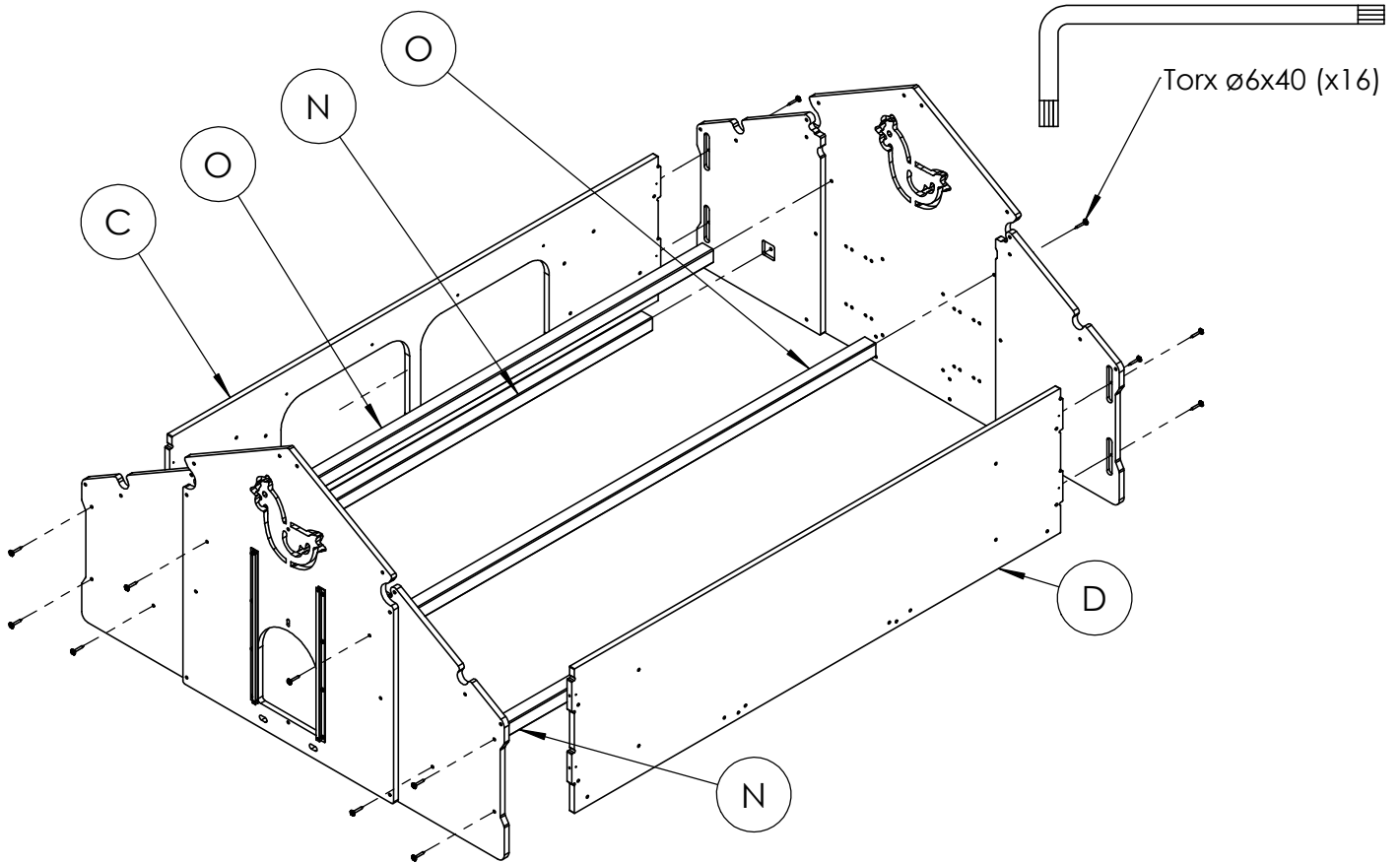

PASO 4

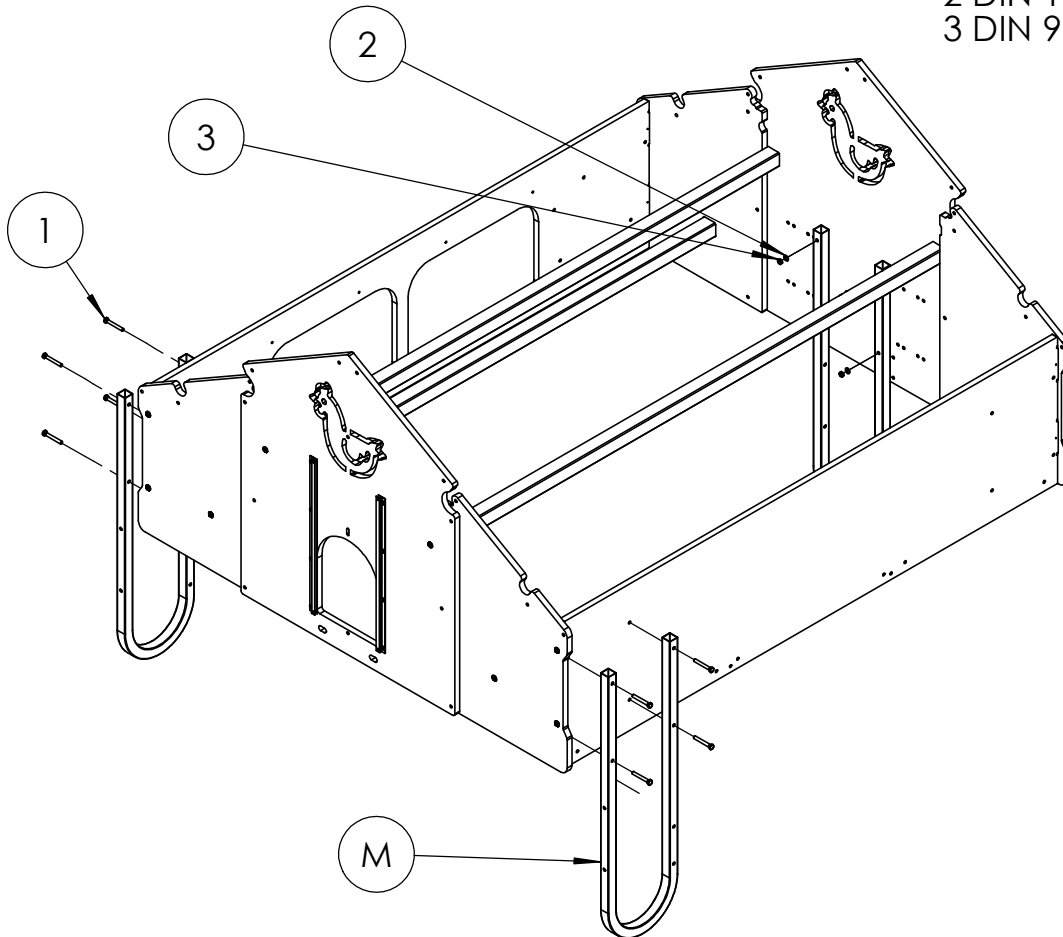

PASO 5

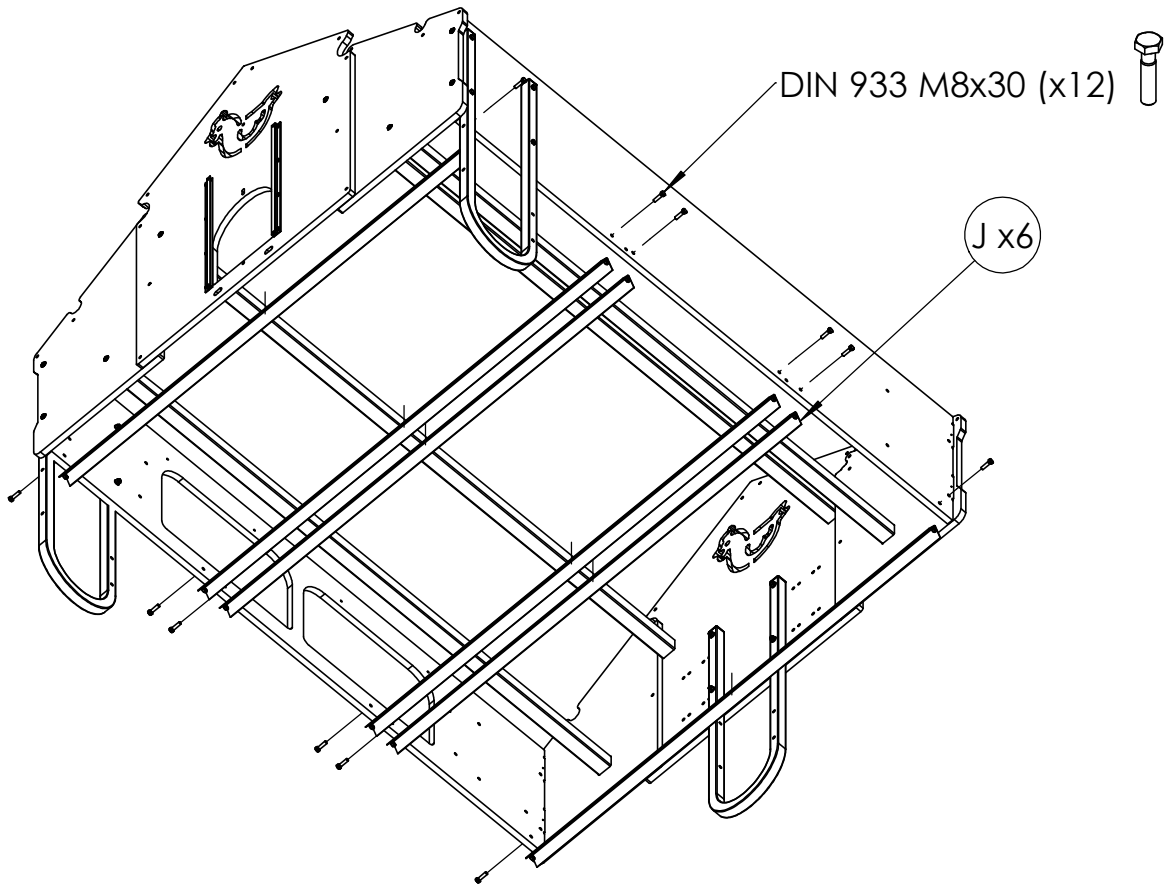

PASO 6

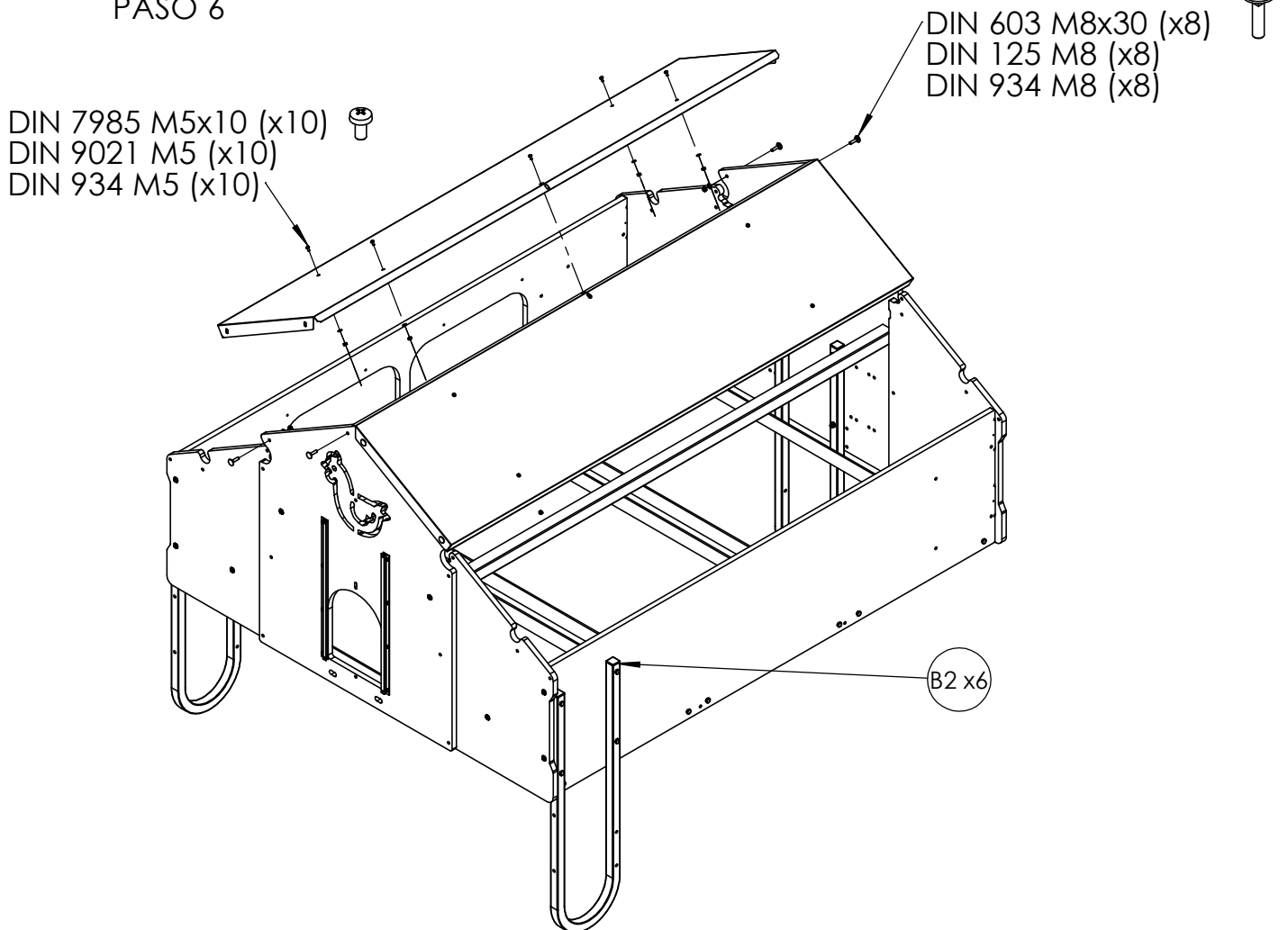

PASO 7

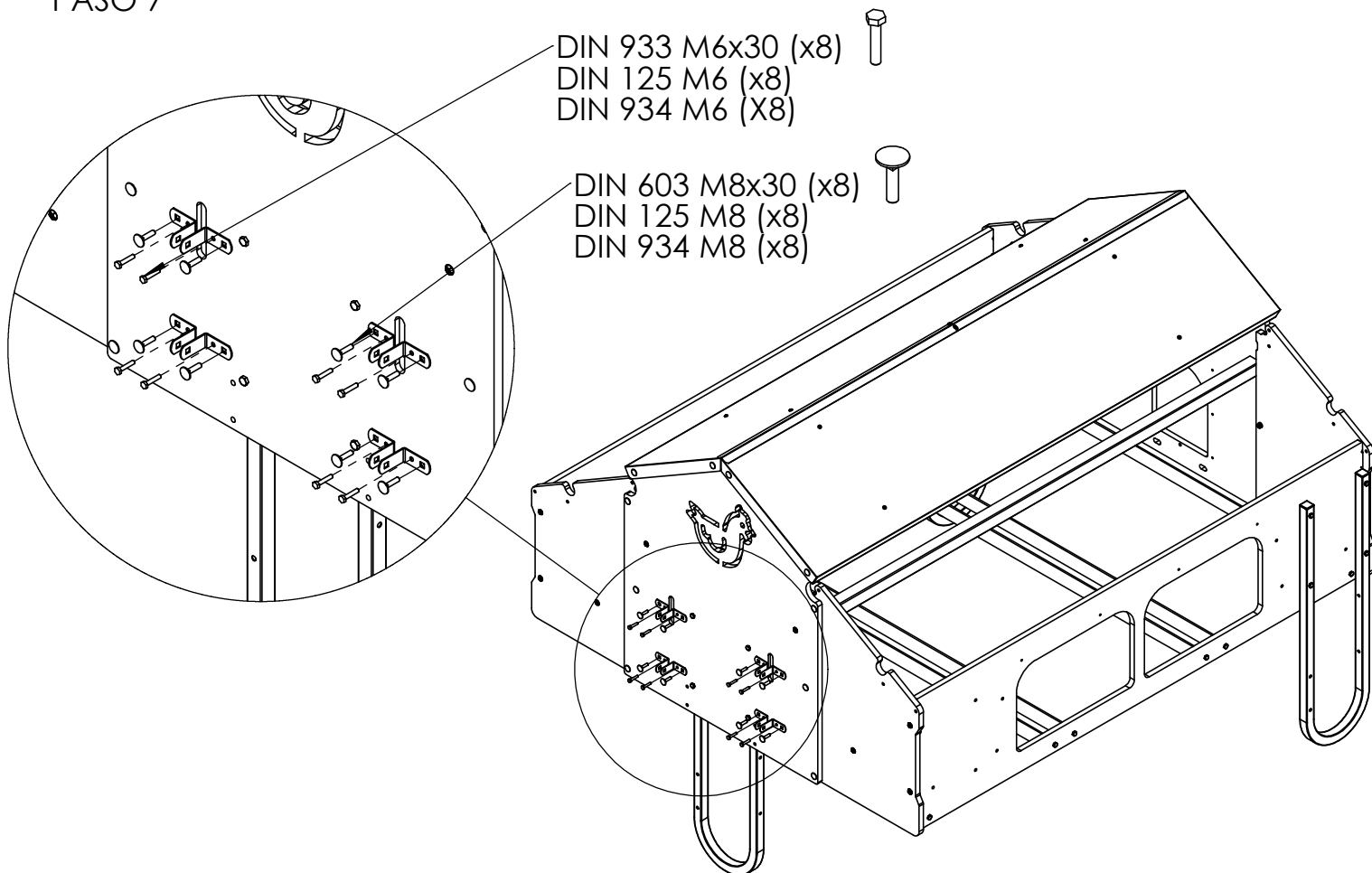

PASO 8

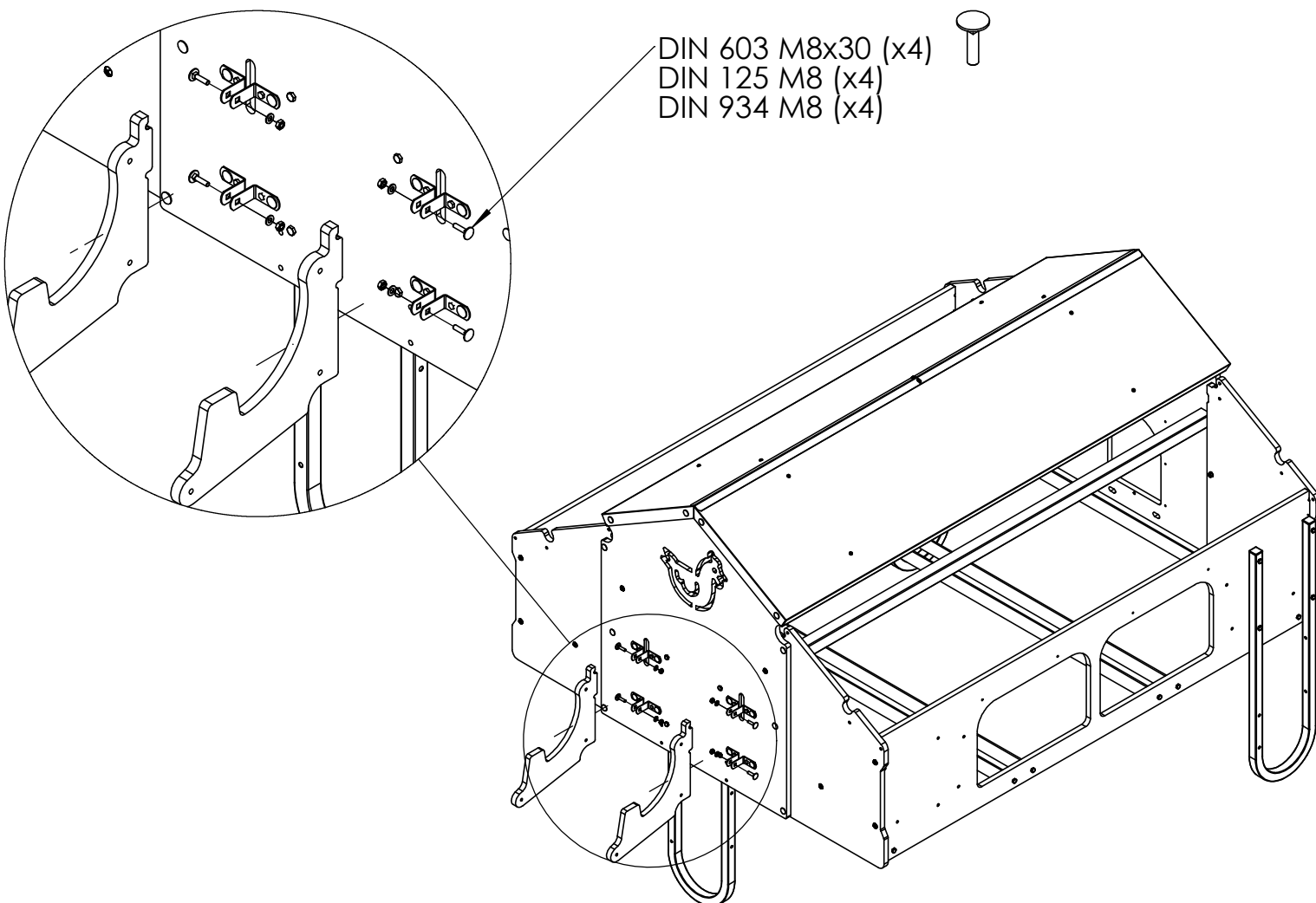

PASO 9

DIN 603 M8x30 (x2)
DIN 125 M8 (x2)
DIN 934 M8 (x2)

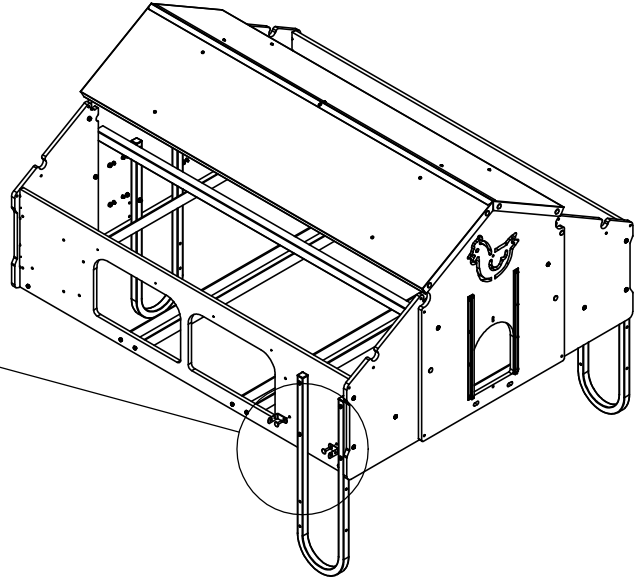
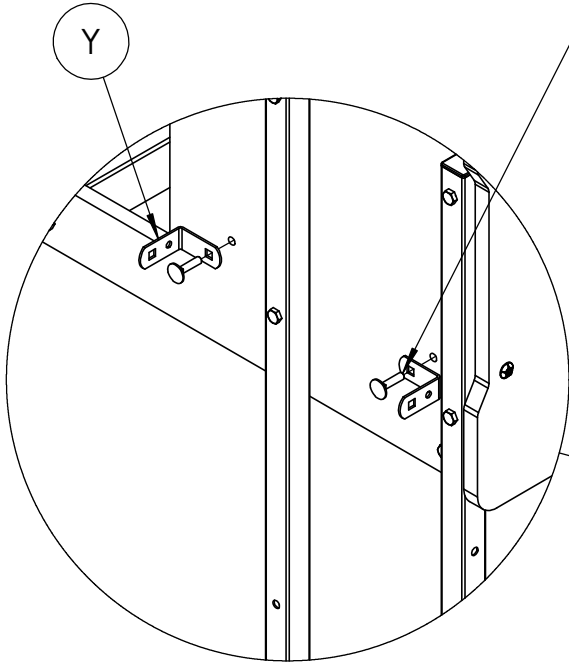

DIN 933 M8x15 (x2)
DIN 125 M8 (x2)
DIN 934 M8 (x2)

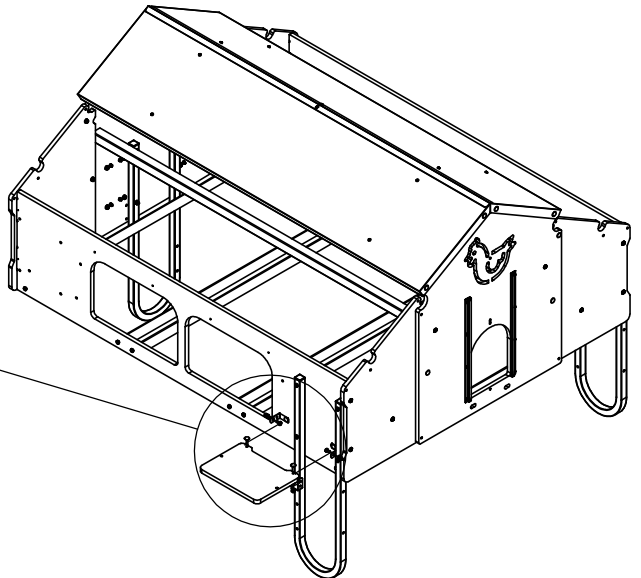
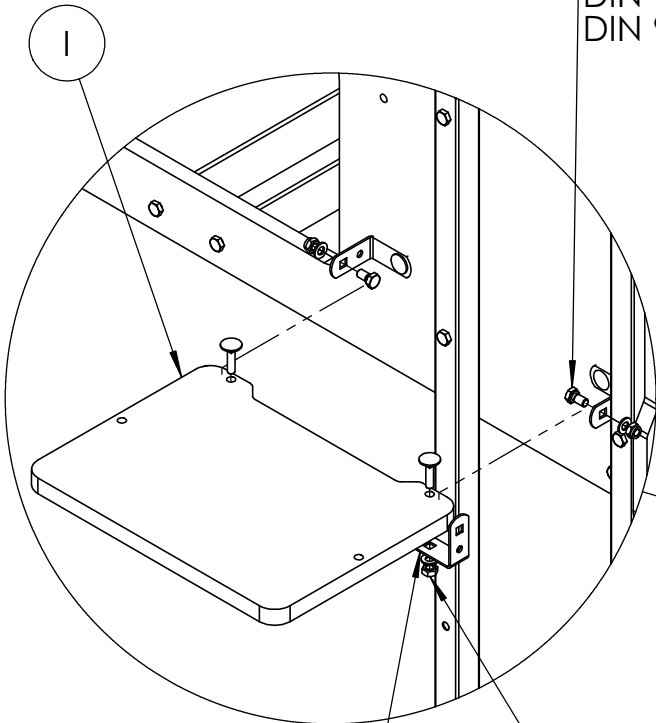

DIN 603 M8x30 (x2)
DIN 125 M8 (x2)
DIN 934 M8 (x2)



PASO 10

- DIN 7985 M5x10 (x8)
- DIN 9021 M5 (x8)
- DIN 934 M5 (x8)

L

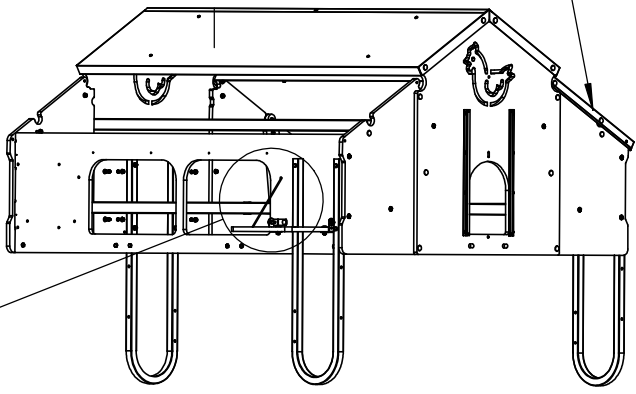
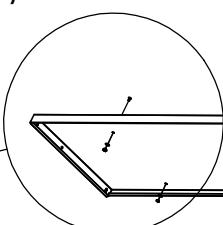
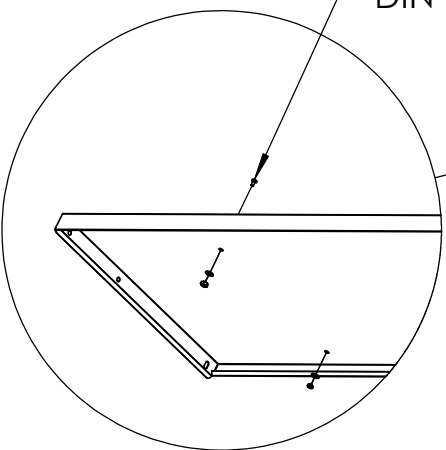

A2

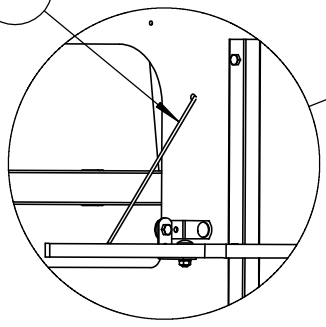

- DIN 603 M8x50 (x4)
- DIN 125 M8 (x4)
- DIN 985 M8 (x4)

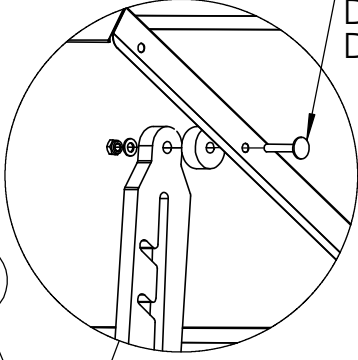

Q

Q

R

- DIN 603 M8x30 (x4)
- DIN 125 M8 (x4)
- DIN 985 M8 (x4)



R

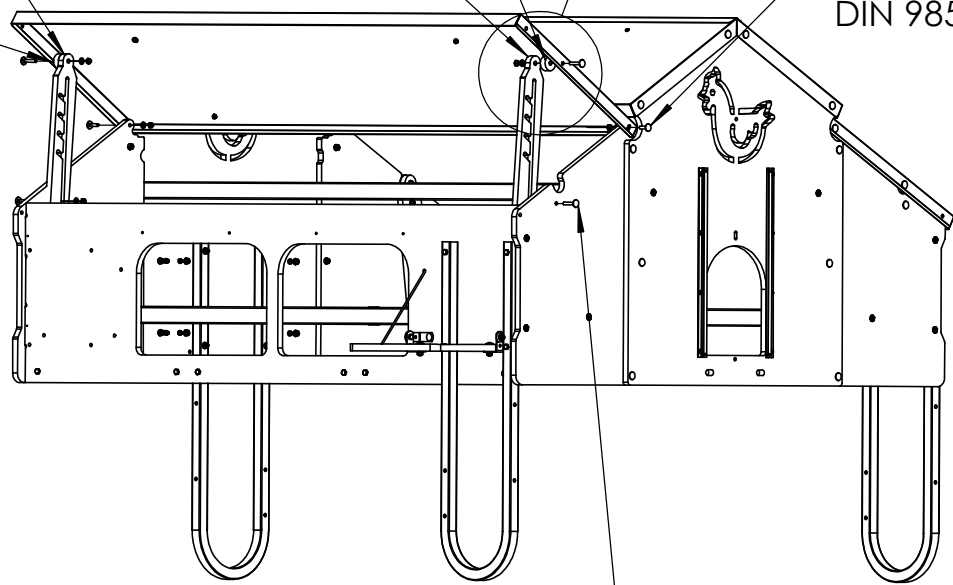

- DIN 603 M8x50 (x4)
- DIN 125 M8 (x4)
- DIN 985 M8 (x4)



PASO 11

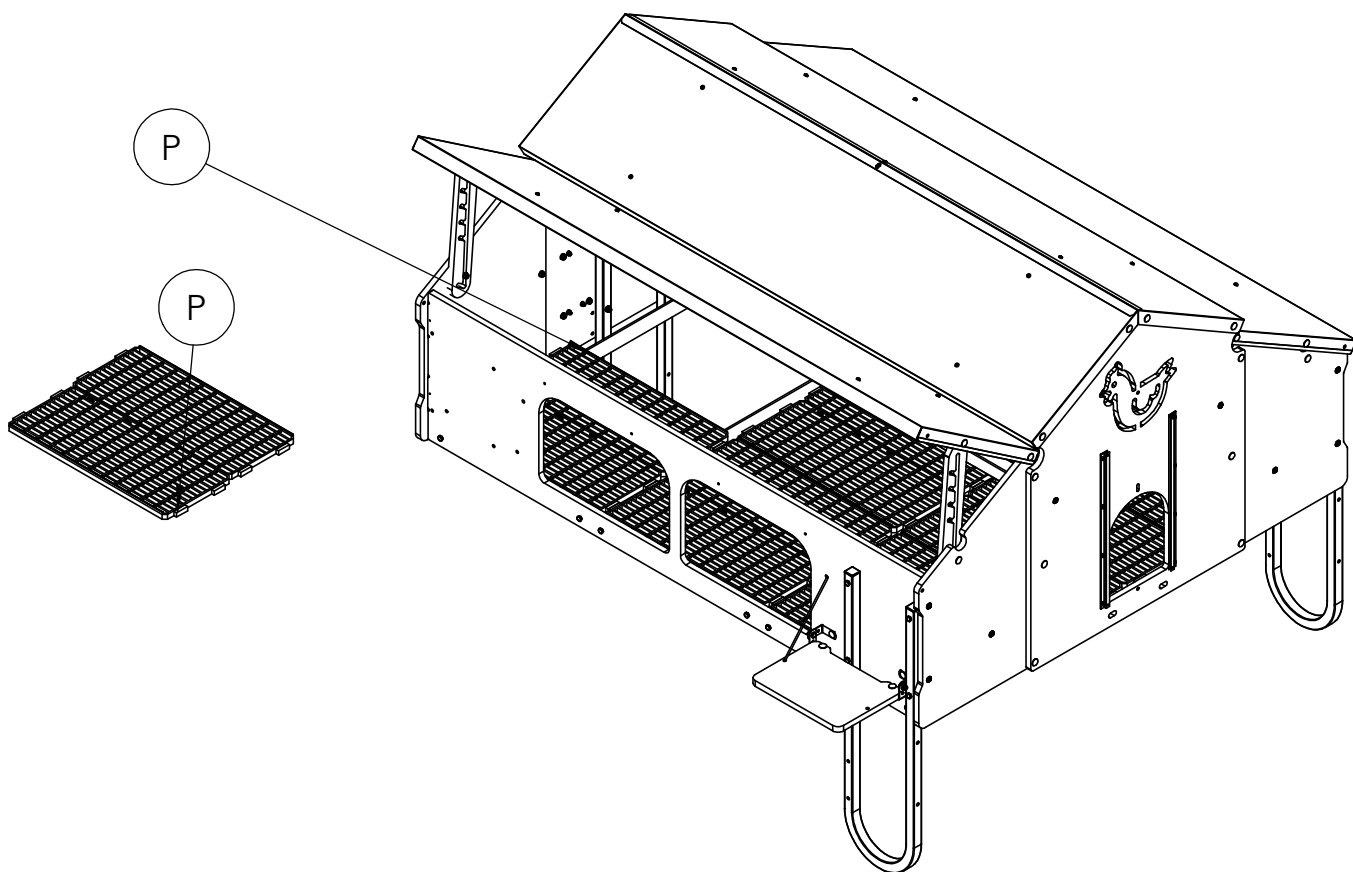

PASO 12

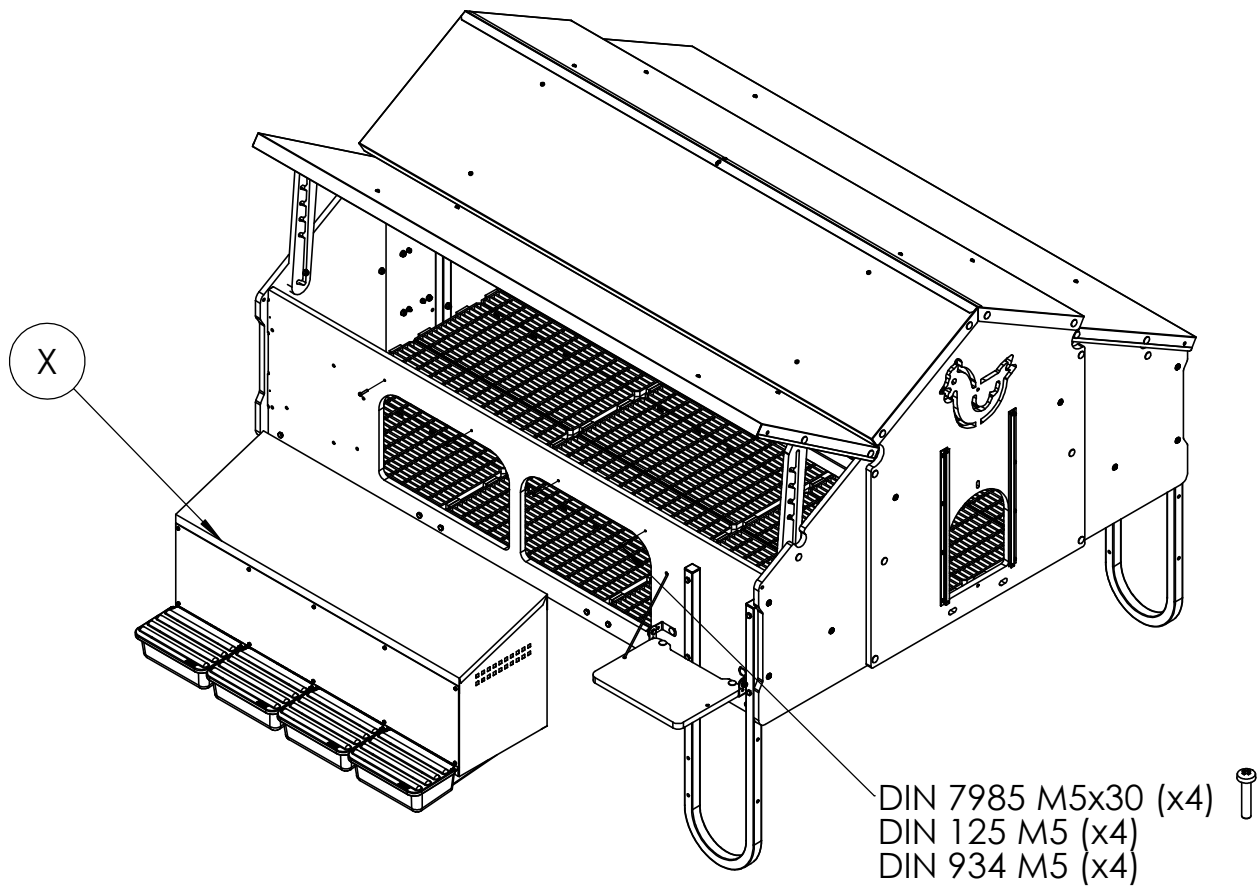

PASO 13

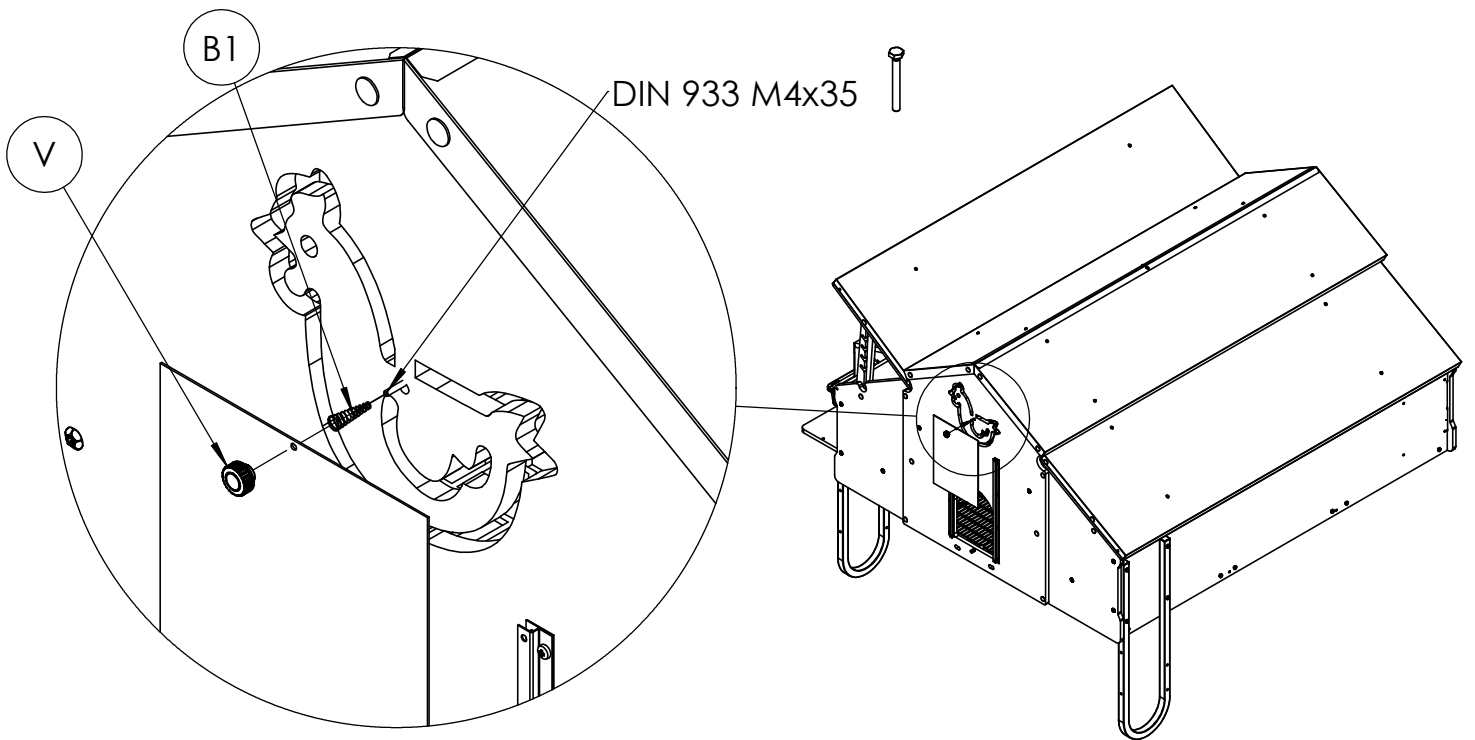
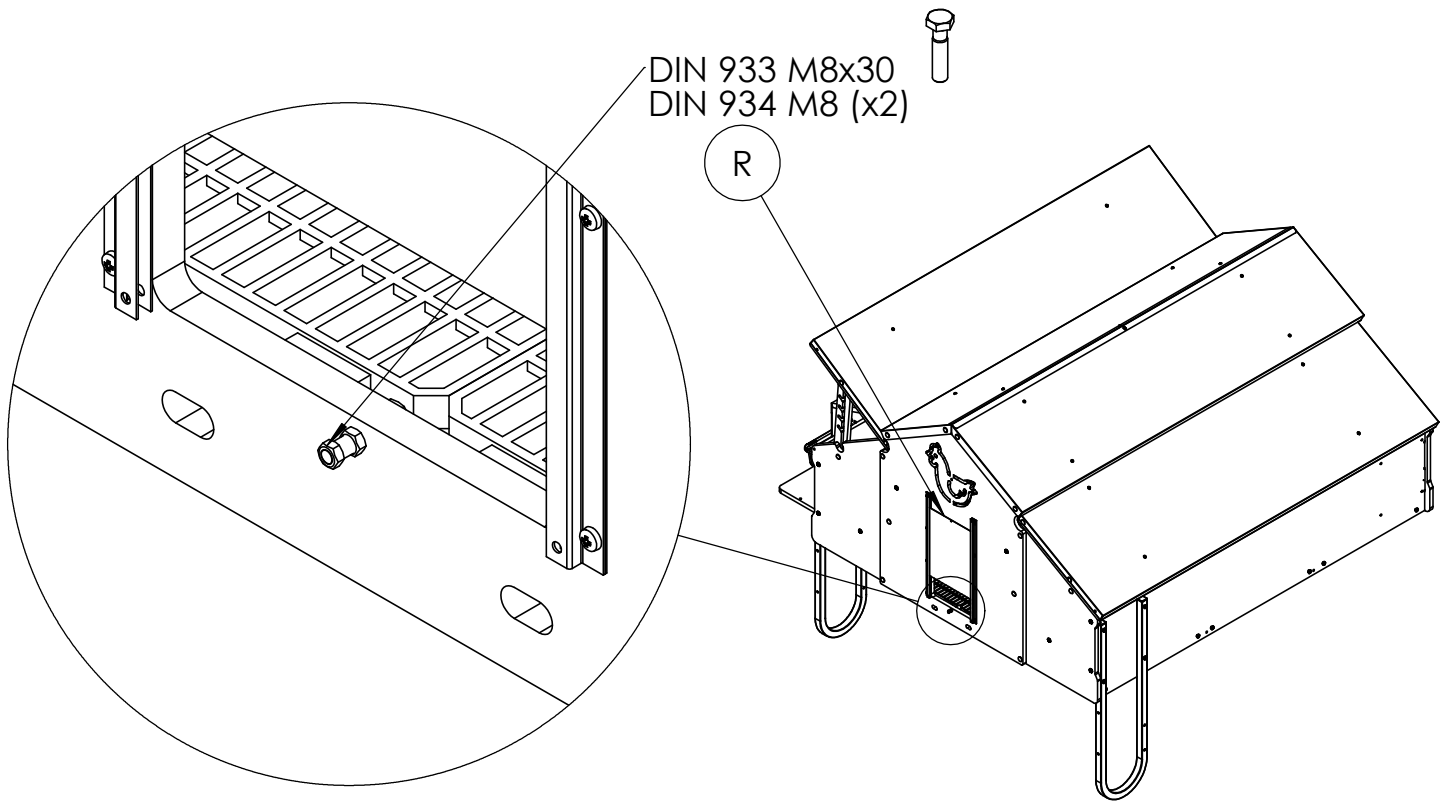

PASO 14

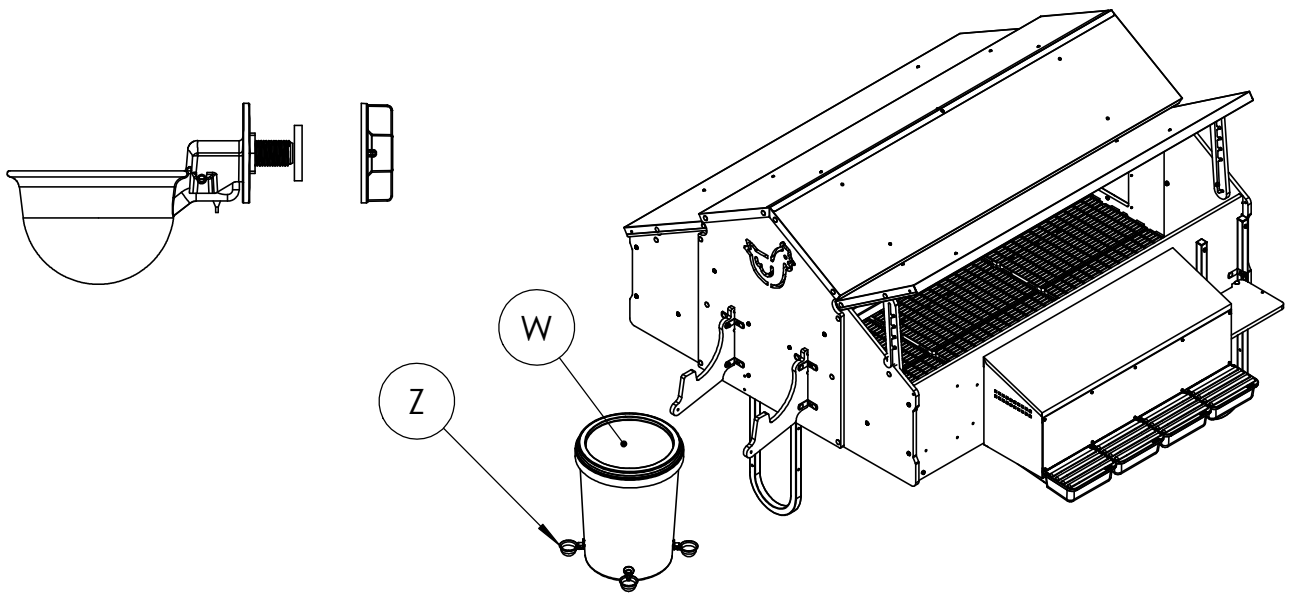

PASO 15

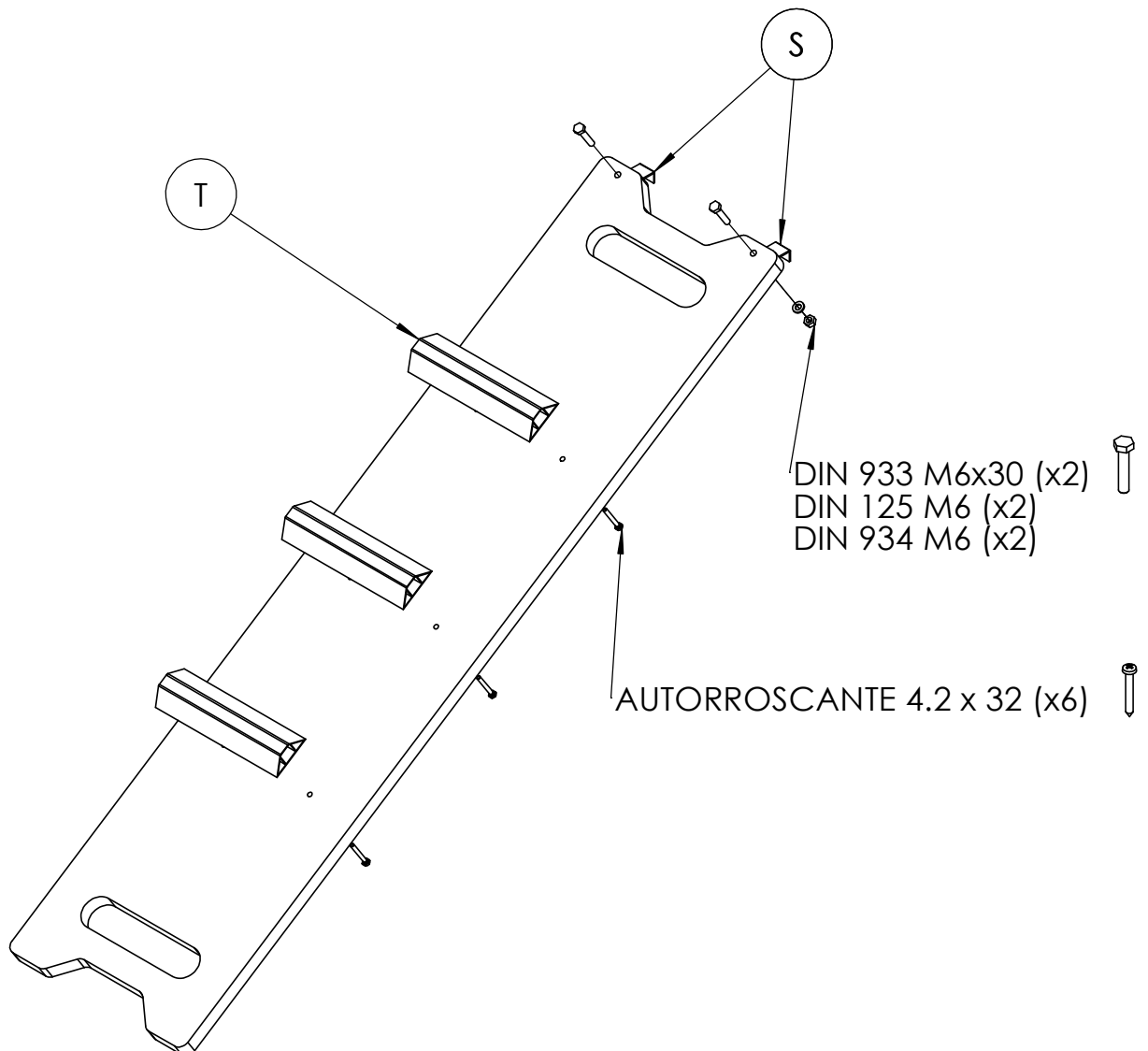

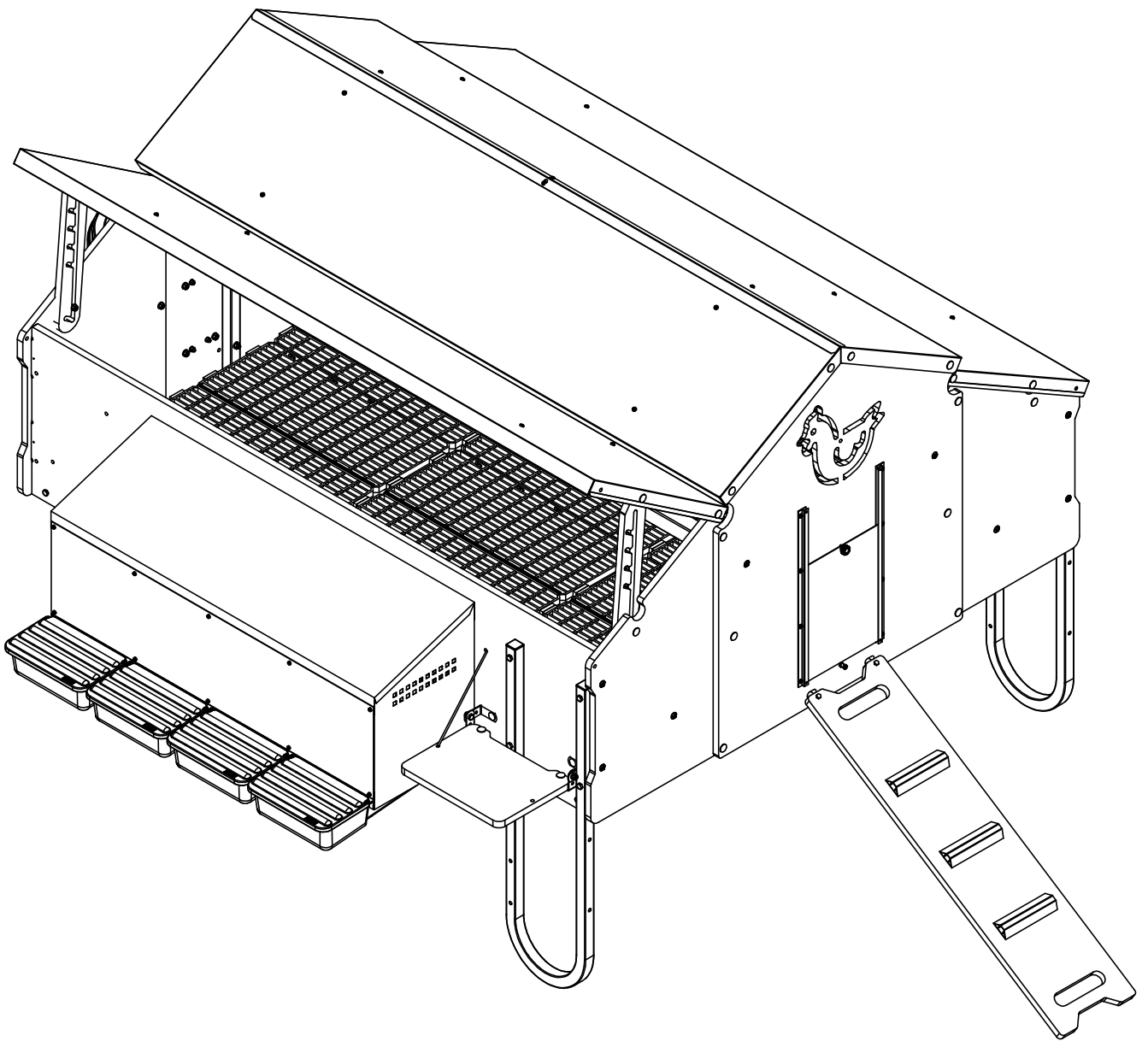
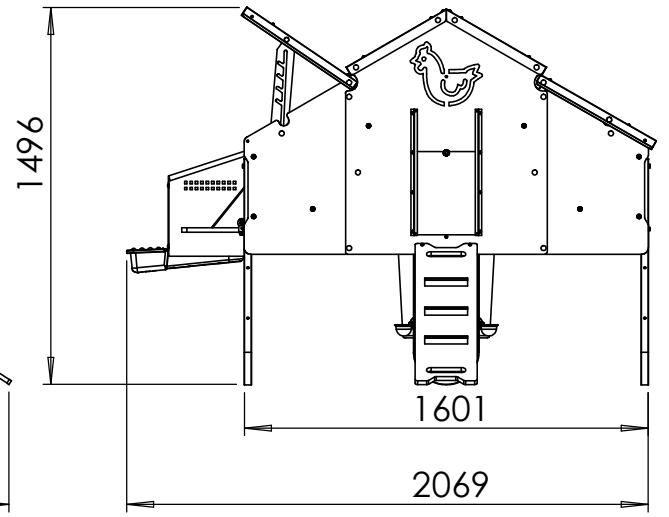
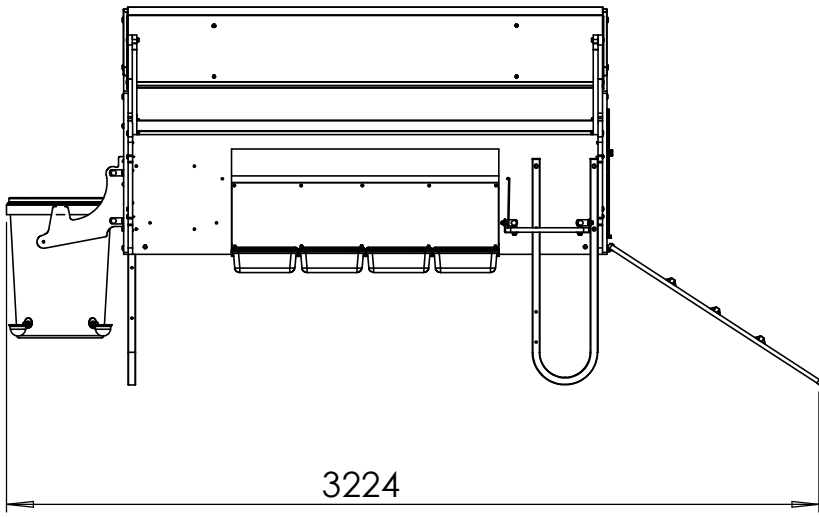

KIT DESPLAZAMIENTO

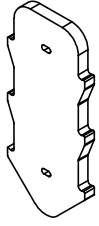

A x2



B x8



C x2

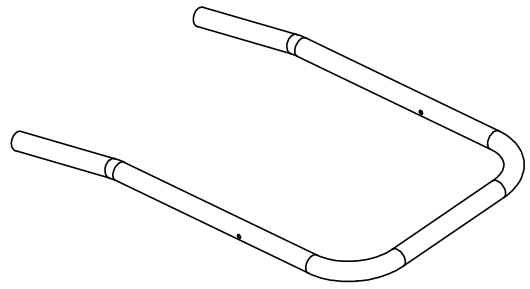

E x1



F x2

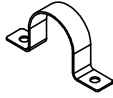

G x2

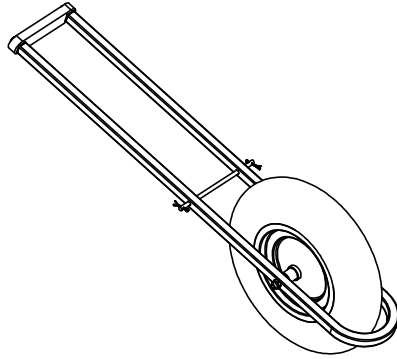

H x2

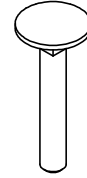

DIN 603 M8x60
x4

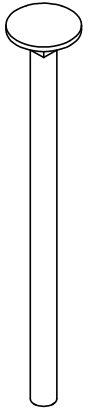

DIN 603 M8x120
x4



DIN 933 M8x50
x2

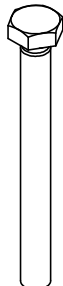

DIN 933 M8x80
x2



DIN 933 M6x30
x4



DIN 985 M8
x2



DIN 9021 M6
x4



DIN 934 M6
x4



DIN 125 M6
x4



DIN 125 M8
x10



DIN 934 M8
x14

PASO 1

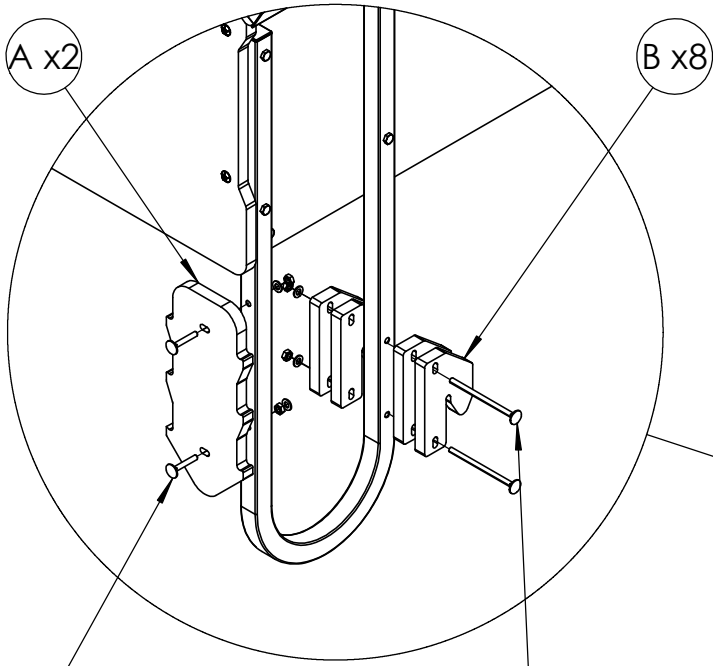

DIN 603 M8x60 (x4)
DIN 125 M8 (x4)
DIN 934 M8 (x4)



DIN 603 M8x120 (x4)
DIN 125 M8 (x4)
DIN 934 M8 (x4)

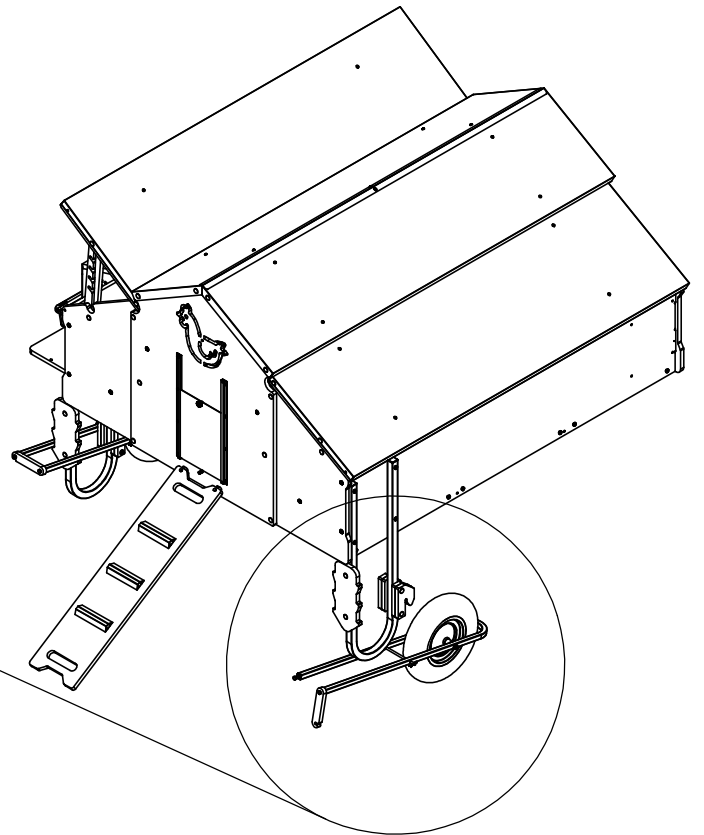
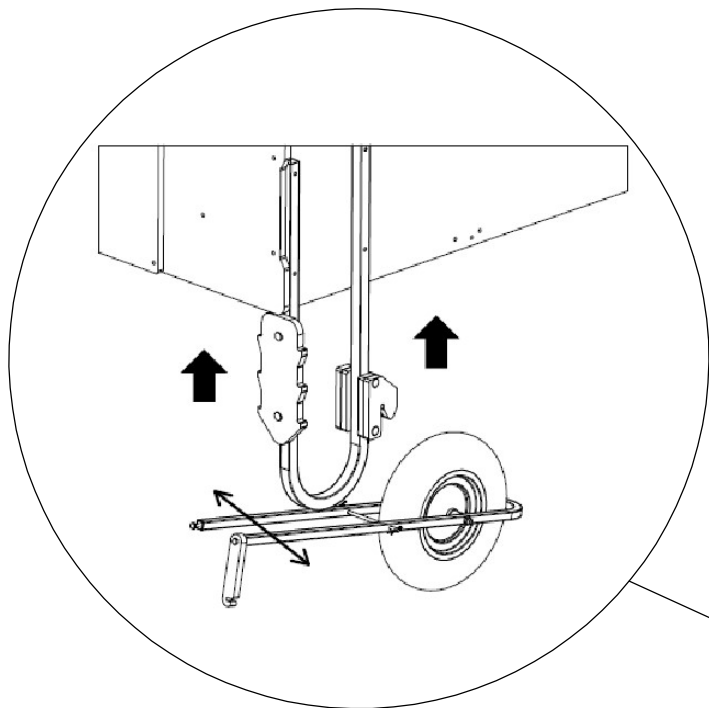
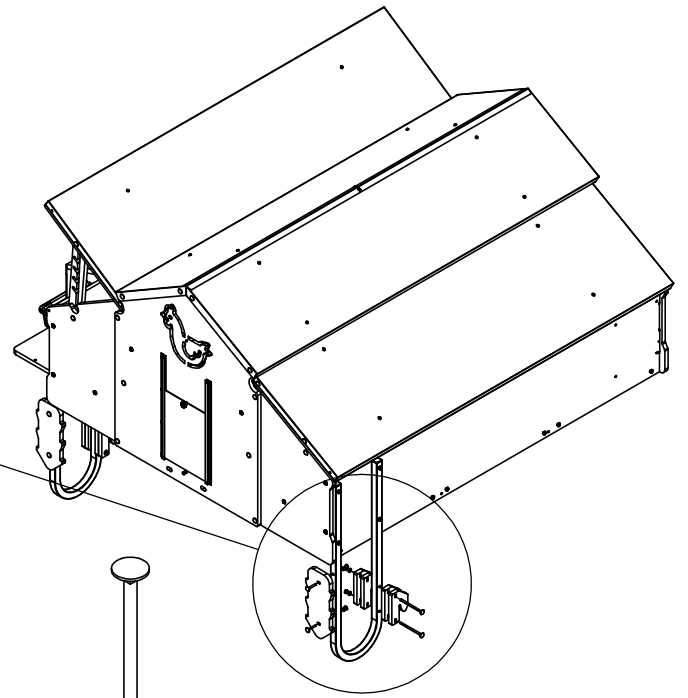

PASO 2

DIN 933 M6x30 (x4)
DIN 125 M6 (x4)
DIN 934 M6 (x4)

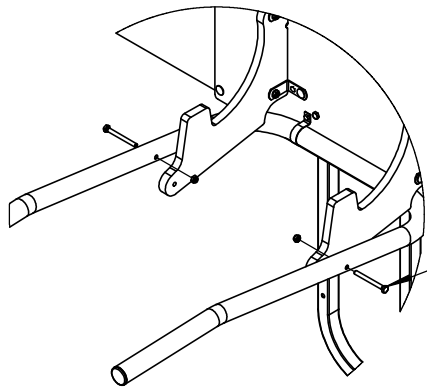
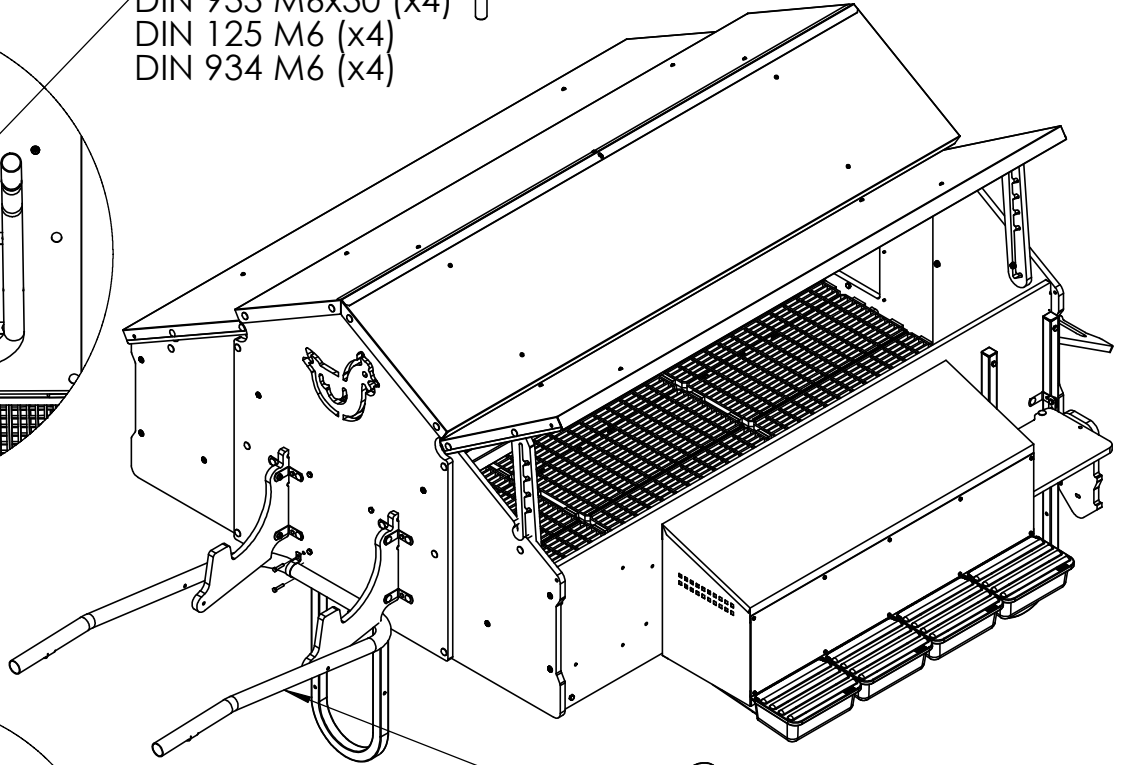
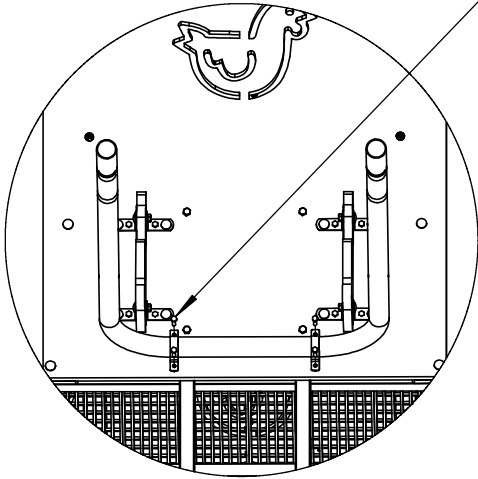

DIN 933 M8x80 (x2)
DIN 985 M8 (x2)

E

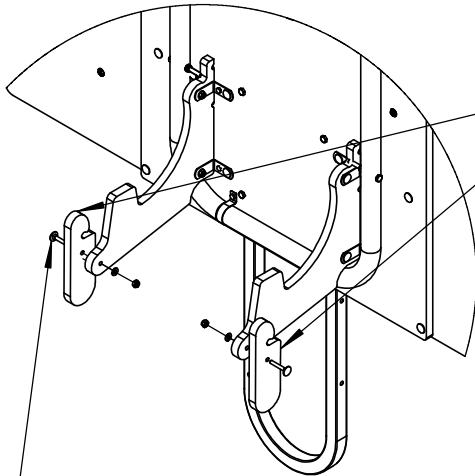

DIN 933 M8 x50 (x2)
DIN 9021 M8 (x2)
DIN 985 M8 (x2)

