

# PEUGEOT

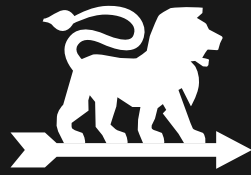

## EnergyDrill-1 6LBE



132623-MANUAL-C-20180227 PEUGEOT OUTILLAGE

**FR** MANUEL D' UTILISATION (Notice originale):  
**NL** HANDBOEK (Vertaling van het oorspronkelijke):  
**ES** MANUAL (Traducción del original):  
**PT** MANUAL (Tradução do manual original):  
**IT** MANUAL (Traduzione dell'avvertenza originale):  
**EN** USING MANUAL (Original manual translation):

*Perceuse colonne*  
*Kolomboormachine*  
*Taladro a columna*  
*Furador a colonna*  
*Trapano a colonna*  
*Drill press*

[peugeot-1810.com](http://peugeot-1810.com)



**FIG. A & B**

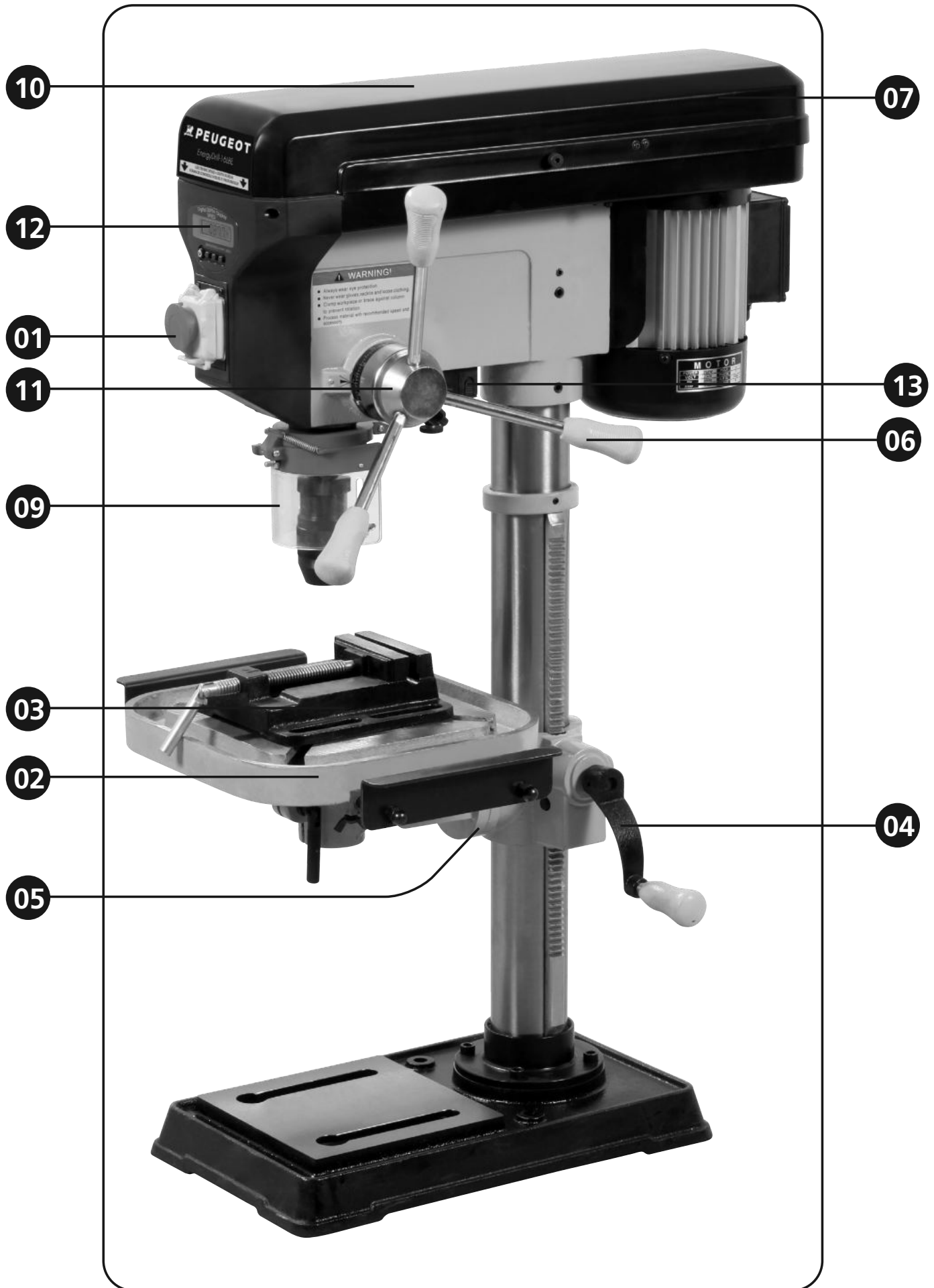



Contenu du carton  
 Inhoud van de doos  
 Conteúdo da caixa  
 Contenido de la caja  
 Contenuto della confezione  
 Contents of the box



**FIG. C**

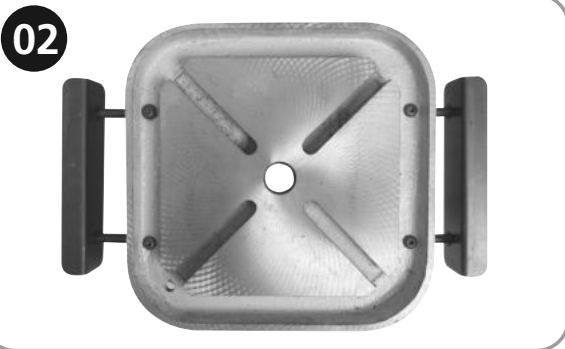
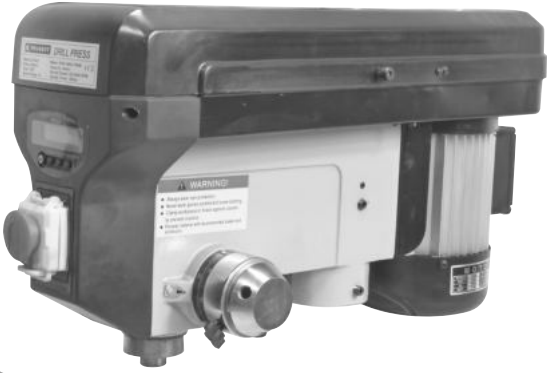

100 mm | N° 4



**B**



Crémaillère  
 Crémaillère  
 De piñón y cremallera  
 pinhão e cremalheira  
 pignone e cremagliera  
 Rack and pinion

**C**



Bague de serrage  
 Klemring  
 Anillo de sujeción  
 Anello di bloccaggio  
 Clamping ring

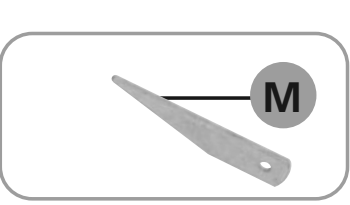
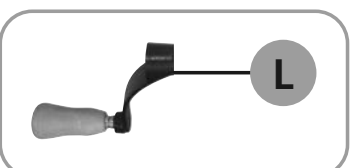
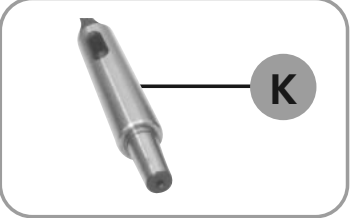
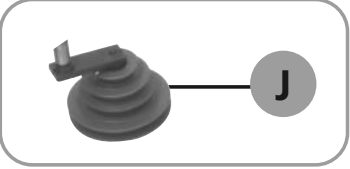
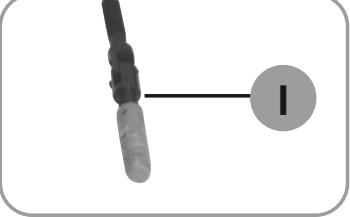
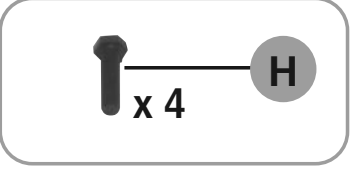
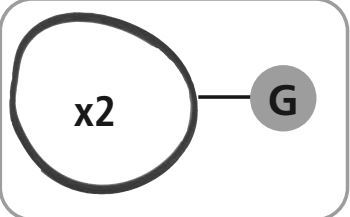
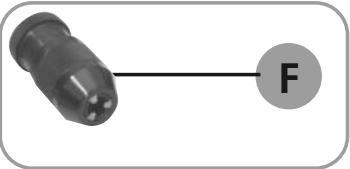
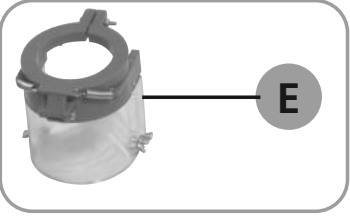

**FIG. D**

**01**

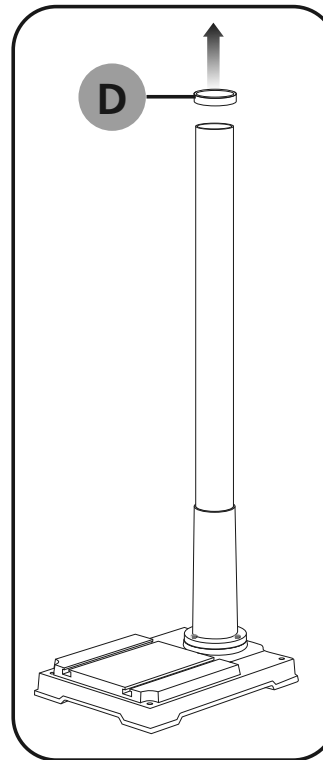
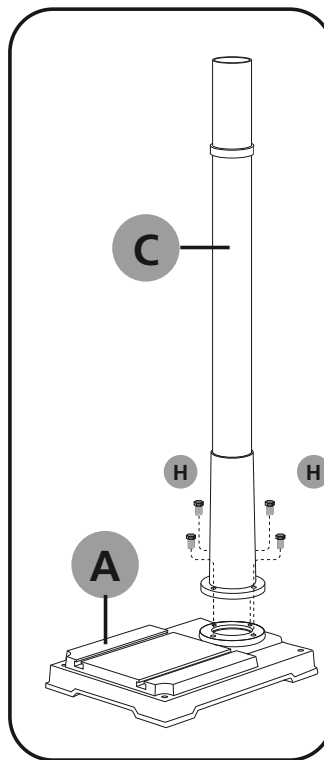
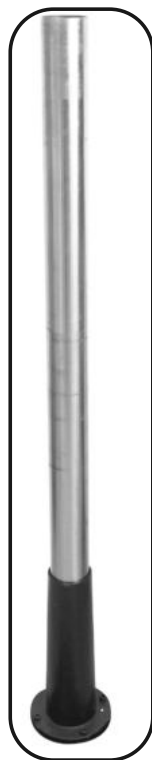

- Visser la colonne (C) sur sa base (4 Vis). Enlever la bague (D) de la crémaillère (B) de la colonne (C) avec une clé hexagonale 3 mm. Placer le support (P) sur l'engrenage.

- Schroef de kolom (C) op de basis (4 schroeven). Reset de ring (D) van het rek (B) van de kolom (C) met een 3 mm inbusleutel. Plaats het medium (P) op de tandwielkast.
- Tornillo de la columna (C) en la base (4 tornillos). Reiniciar el anillo (D) de la cremallera (B) de la columna (C) con un 3 mm llave hexagonal. Coloque el medio (P) en el engranaje.
- Parafuso da coluna (C) sobre a base (4 parafusos). Redefinir o anel (D) da cremalheira (B) da coluna (C) com de 3 mm a chave sextavada. Coloque o meio (P) sobre a engrenagem.
- Avvitare la colonna (C) sulla base (4 viti). Resettare l'anello (D) del cestello (B) della colonna (C) con una chiave esagonale 3 mm sclusa. Posizionare il supporto (P) sull'ingranaggio.
- Screw the column (C) on the base (4 screws). Reset the ring (D) of the rack (B) of the column (C) with a 3 mm hexagonal wrench. Place the medium (P) on the gear.

**02**

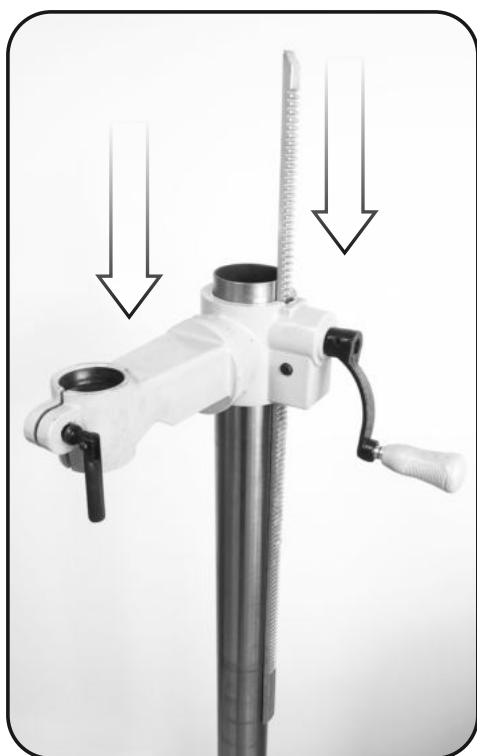

**Insérer la crémaillère (B) dans le support de la table et glisser les pièces dans la colonne simultanément. La partie biseautée de la crémaillère est positionnée entre la colonne et la bride. La partie supérieure de la crémaillère est positionnée de façon similaire entre la colonne et la bague.**

Plaats het rek in de flens van de kolom en de glijstukken in de kolom tegelijk. De smalle flens van het rek is gepositioneerd tussen de mast en de flens. Het bovenste gedeelte van het rek is gepositioneerd tussen de kolom en soortgelijke ring.

Introduzca la rejilla en la brida de la columna y las piezas de deslizamiento en la columna simultáneamente. La pequeña brida del bastidor está situado entre la columna y la brida. La parte superior del bastidor está situado entre la columna y el anillo similar.

Inserir o suporte no rebordo da coluna e as peças de deslizamento da coluna simultaneamente. O pequeno rebordo da prateleira está posicionado entre a coluna e a flange. A parte superior da prateleira está posicionado entre a coluna e um anel semelhante.

Inserire la cremagliera nella flangia della colonna e le parti di scorrimento nella colonna simultaneamente. La piccola flangia del rack è posizionato tra la colonna e la flangia. La parte superiore della cremagliera è posizionato tra la colonna e anello simile.

Insert the rack in the flange of the column and the slide pieces in the column simultaneously. The small flange of the rack is positioned between the column and the flange. The upper part of the rack is positioned between the column and similar ring.

02

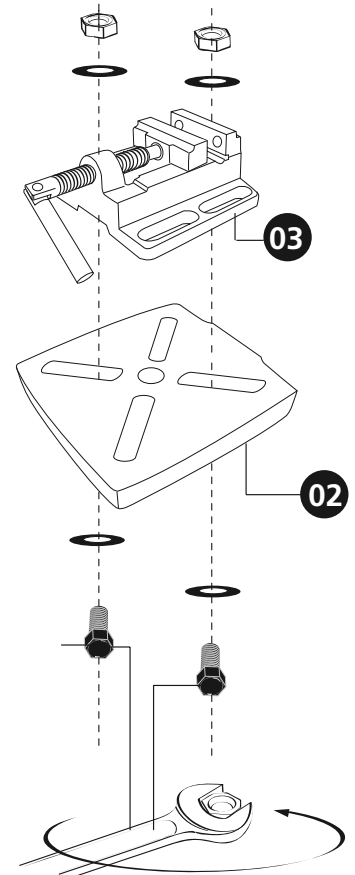
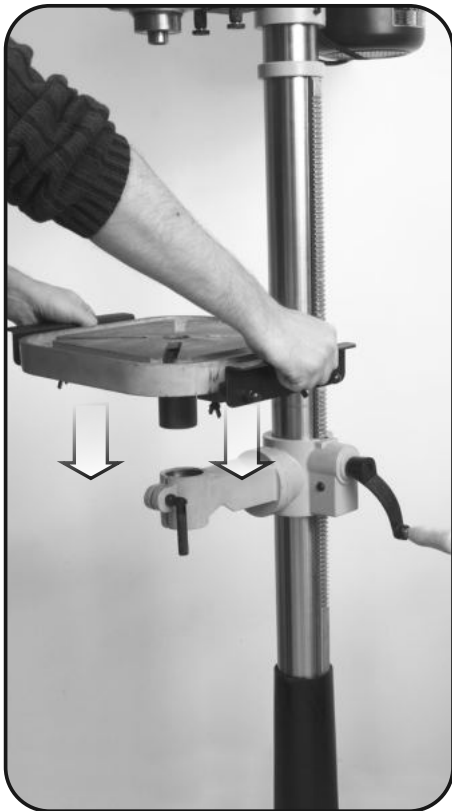

03

- Positionner les 2 poulies. Mettre la courroie en place sur le première poulie, puis la tendre jusqu'à la deuxième poulie.
- Plaats de 2 katrollen. Zet de riem op zijn plaats op de eerste katrol, dan rek het aan de tweede katrol.
- Posicione las 2 poleas. Poner la correa en su lugar en la primera polea, y luego estirla hasta la segunda polea.
- Posicione as 2 roldanas. Coloque o cinto no lugar na primeira polia, em seguida, esticá-lo para a segunda polia.
- Posizionare le 2 pulegge. Mettere la cinghia in posizione sulla prima puleggia, quindi allungarla alla seconda puleggia.
- Position the 2 pulleys. Put the belt in place on the first pulley, then stretch it to the second pulley.

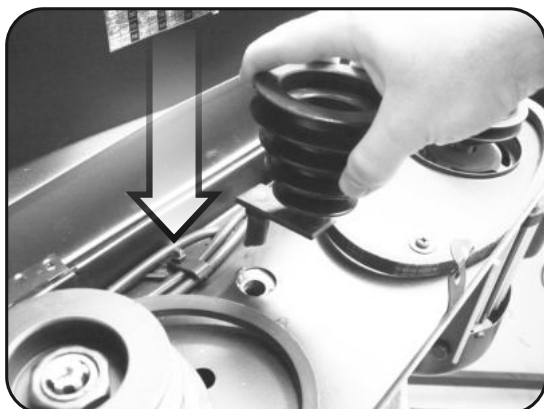

03

- Positionner la tête sur la colonne et serrer avec les vis.

**Visser les trois poignées du cabestan sur leur axe ; droite ou gauche suivant l'utilisateur.**

- Bevestig de kop om de kolom en draai de schroef.  
Schroef de drie kaapstander handvatten om hun as;  
Rechts of links, afhankelijk van de gebruiker.

- Coloque la cabeza de la columna y apriete el tornillo.  
Atornille los tres asas cabrestante sobre su eje;  
Derecha o izquierda dependiendo del usuario.

- Coloque a cabeça para a coluna e aperte o parafuso.  
Aperte os três alças cabrestante sobre seu eixo;  
Direita ou esquerda, dependendo do usuário.

- Fissare la testa alla colonna e serrare la vite.  
Avvitare le tre maniglie ancora sul loro asse;  
Destra o sinistra a seconda dell'utente.

- Attach the head to the column and tighten the screw.

Screw the three capstan handles on their axis; right or left depending on the user.

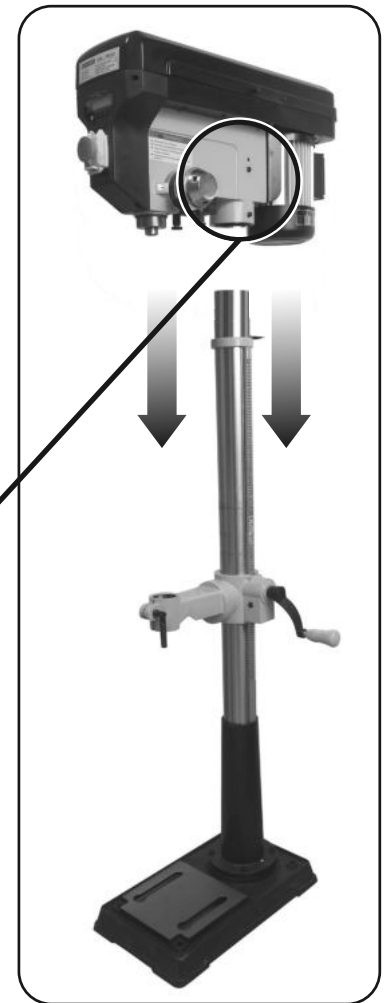
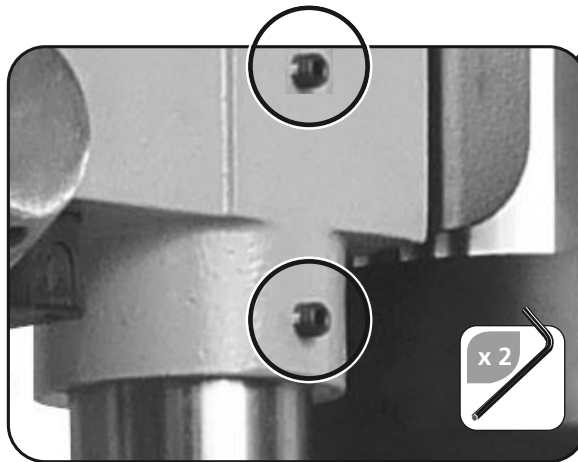

**Cabestan - Kaapstander - Cabezal móvil - Cabrestante - L'argano - Capstan**

06



**Cabestan pour gaucher**  
Boeganker voor Lefty  
Cabrestante para zurdo  
Cabrestante para Lefty  
Argano per Lefty  
Left hand capstan



**Cabestan pour droitier**  
Boeganker voor rechtshandig  
Cabrestante para derecha  
Cabrestante para destro  
Argano per mano destra  
Capstan for right handed

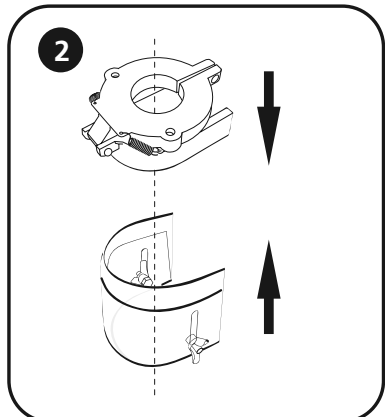
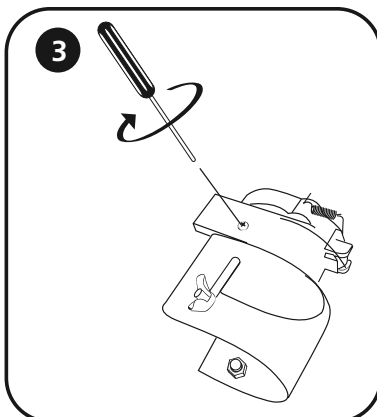

03



**Fixer le carter de protection AVANT le mandrin**  
 Bevestig de bewaker VOORDAT boorkop  
 Fije el protector ANTES mandril  
 Anexe o guarda ANTES chuck  
 Montare la guardia PRIMA mandrino  
 Attach the guard BEFORE chuck

**Serrer le carter (E) sur l'axe de la broche à l'aide de la vis cruciforme (a) située sur le côté**  
 Draai de behuizing aan de as van de spil met de kruiskopschroef (a) aan de zijkant  
 Apriete la caja en el eje del eje con el tornillo Phillips (a) en la parte  
 Apertar o invólucro sobre o eixo de rotação da árvore com o parafuso Phillips (a) no lado  
 Serrare l'alloggiamento sull'asse del mandrino con la vite Phillips (a) sul lato  
 Tighten the housing on the axis of the spindle with the Phillips screw (a) on the side

4

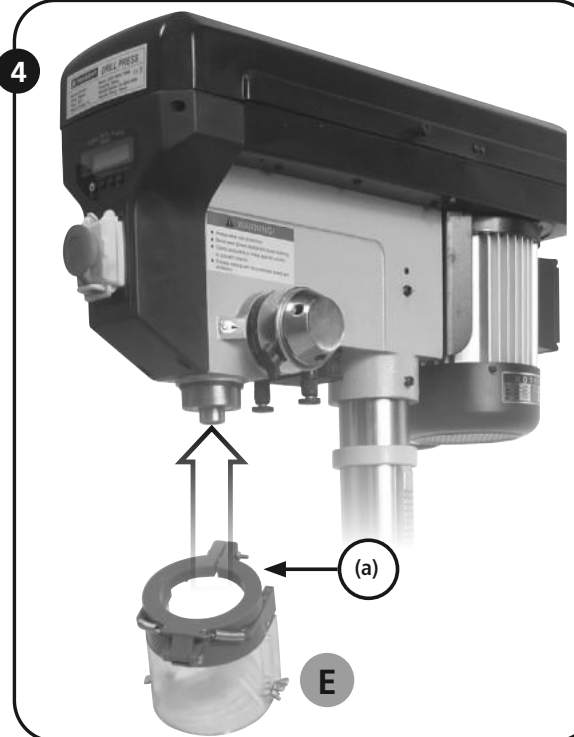

04

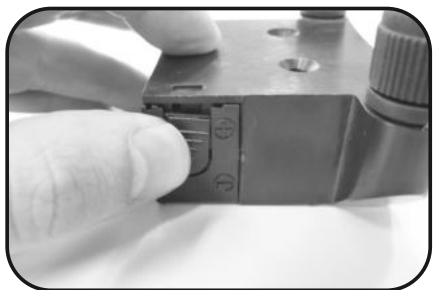

LASER



2 x AAA (LR03) 1,5 V



05

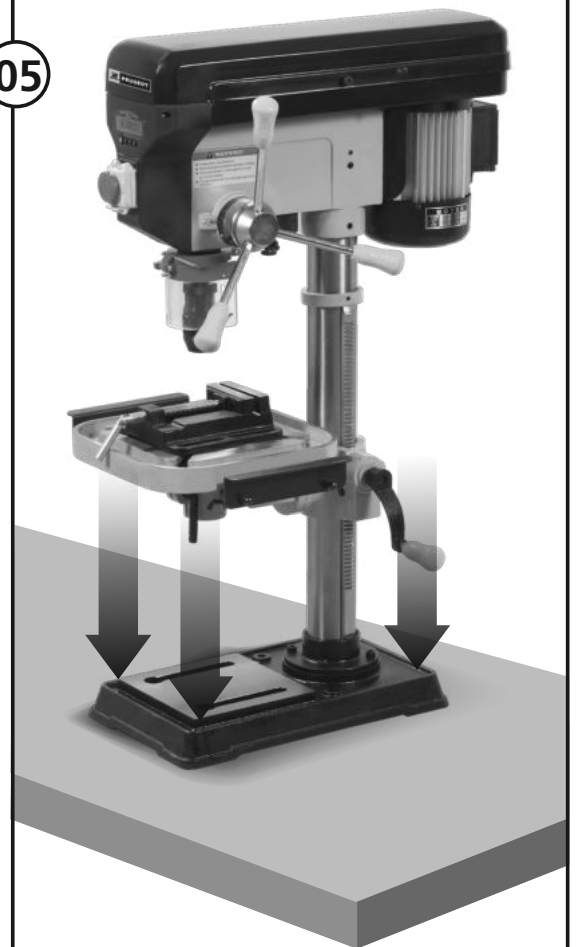

01

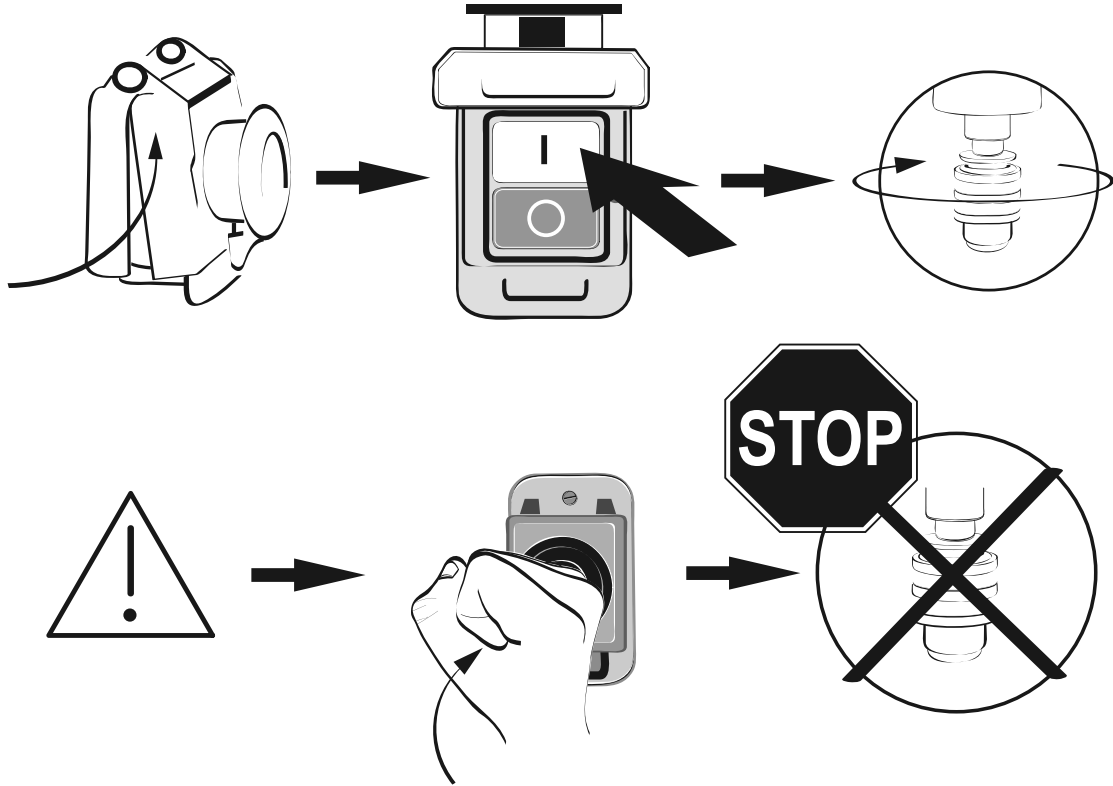
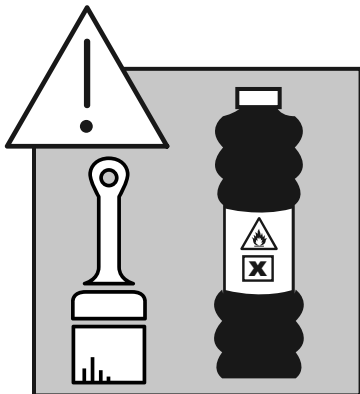

FIG. E

02



Dégraissier  
 Ontvet  
 Desengrasar  
 Desengravar  
 Sgrassare  
 Degrease

Montage du mandrin  
 Montage van de boorkop  
 Montaje del mandril  
 Assembléia (Edição) da pancada  
 Montaggio del mandrino  
 Assembly of the chuck

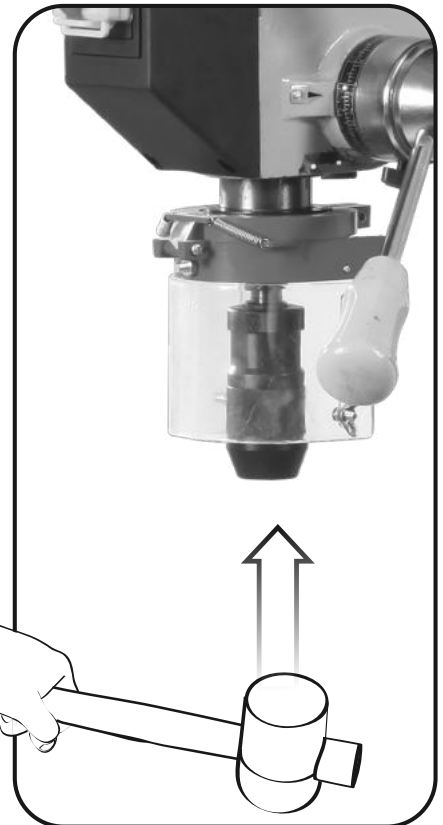
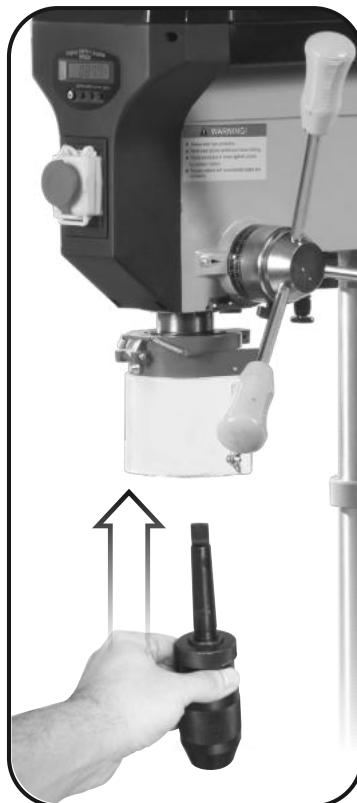
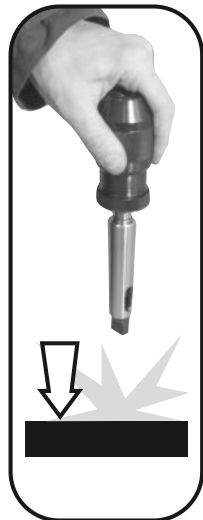
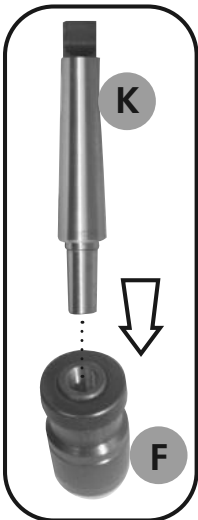



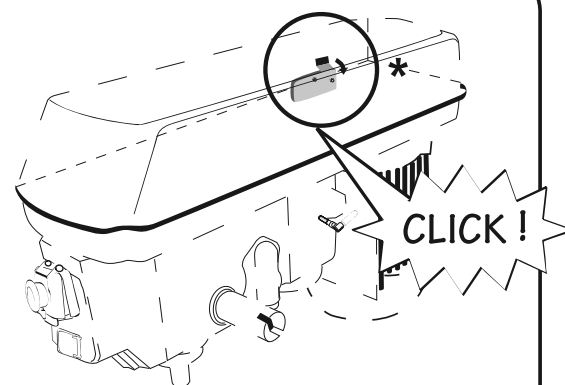
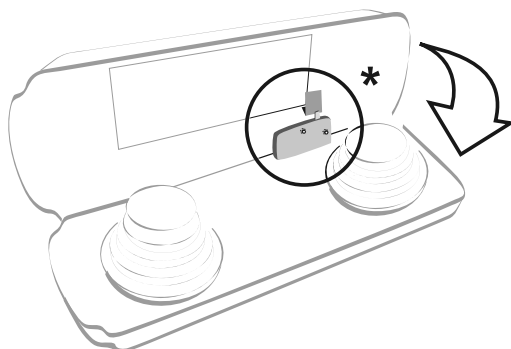

**Contact de sécurité :**  
 la perceuse ne démarre pas si le capot supérieur est ouvert  
**Veiligheid contact:**  
 de boor niet starten als de bovenklep open  
**Contacto de seguridad:**  
 el taladro no se inicia si la cubierta superior está abierta  
**Contato Segurança:**  
 a broca não começar se a tampa superior está aberta  
**Contatto di sicurezza:**  
 il trapano non si avvia se il coperchio superiore è aperto  
**Safety contact:**  
 the drill does not start if the top cover is open

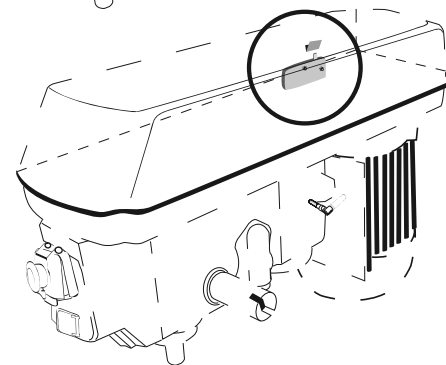
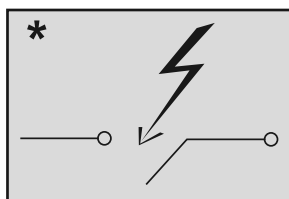

02

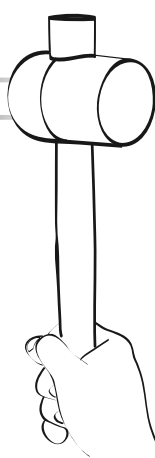
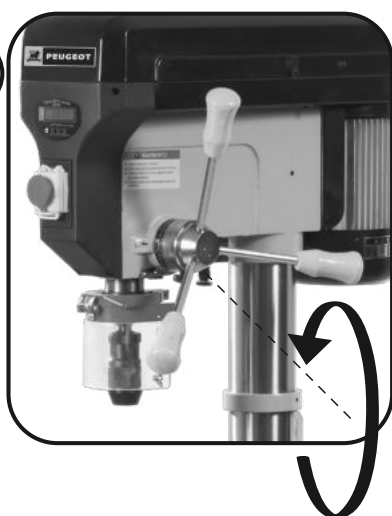

**Démontage du mandrin - De doorn verwijderen -**  
**Extracción del mandril - A remoção do mandril -**  
**Rimozione del mandrino - Removing the mandrel**

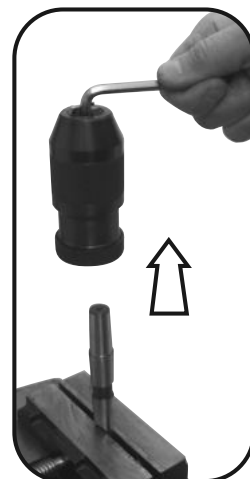
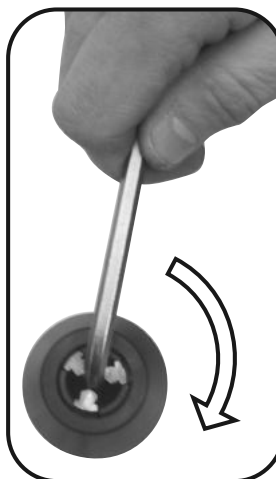
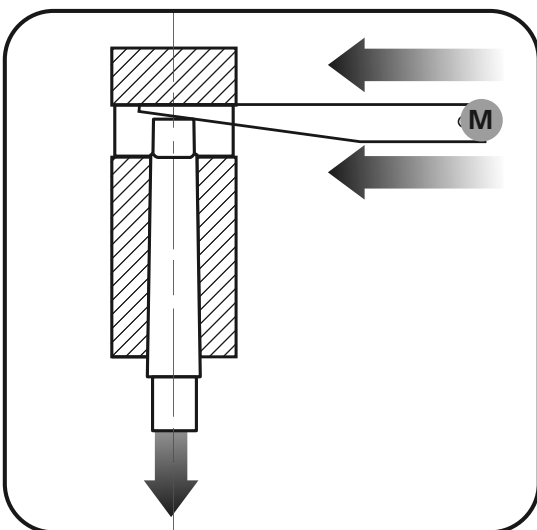

03

### Utilisation des extensions de table

Met behulp tafelerbreidingen

El uso de extensiones de la mesa

Usando extensões de mesa

Utilizzando le estensioni da tavolo

Using table extensions

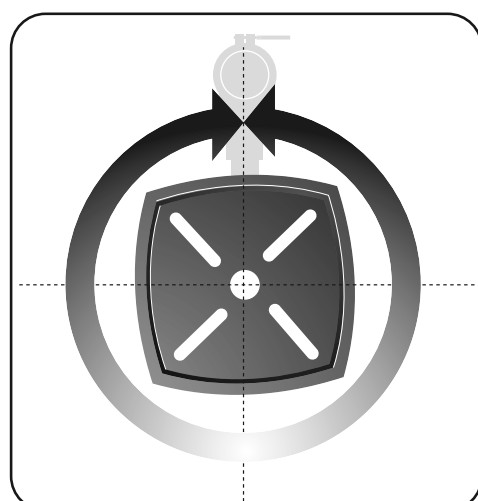
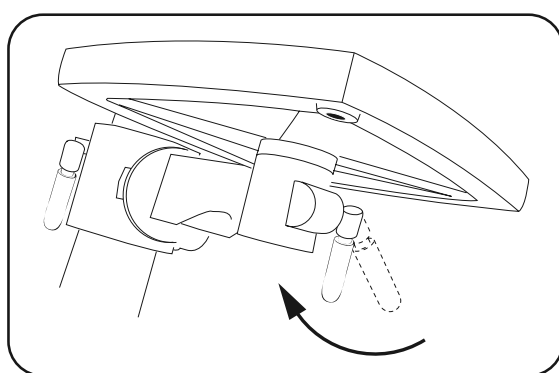
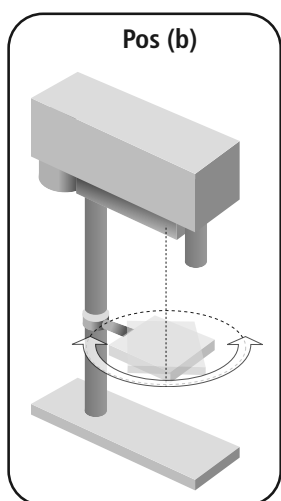
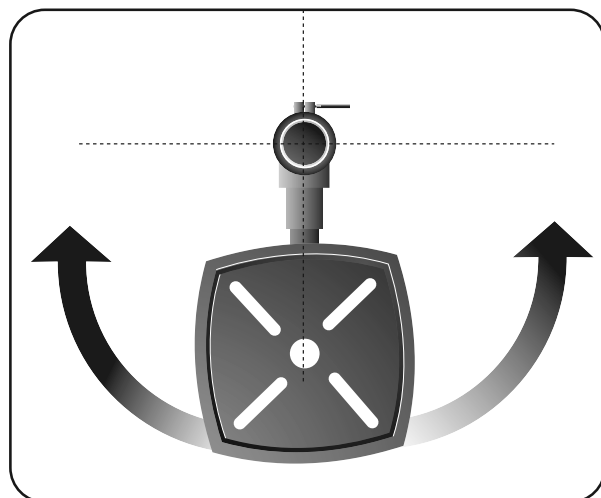
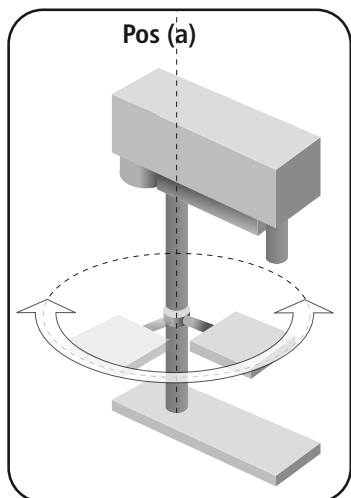
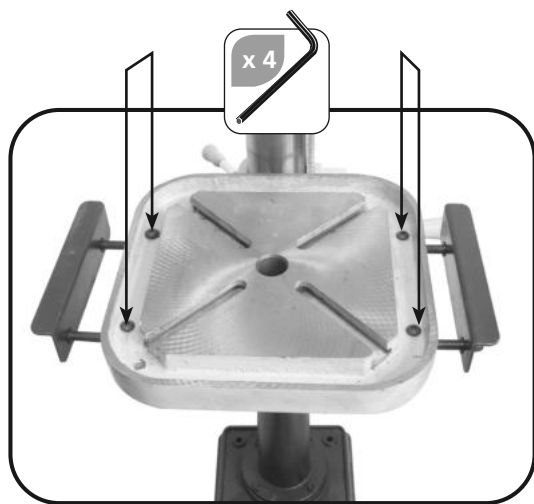



03

Pos (c)

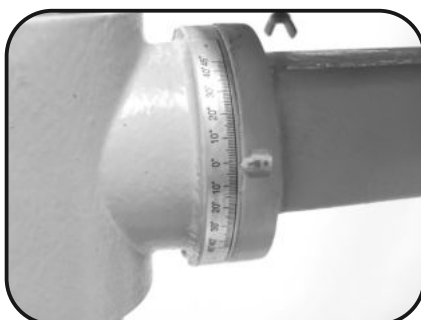
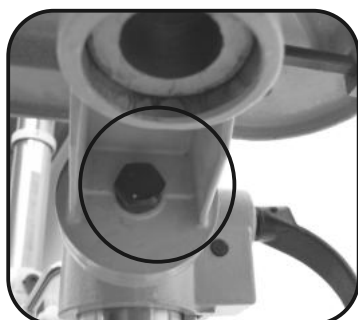
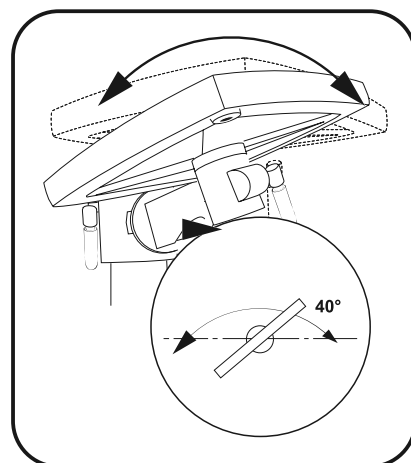
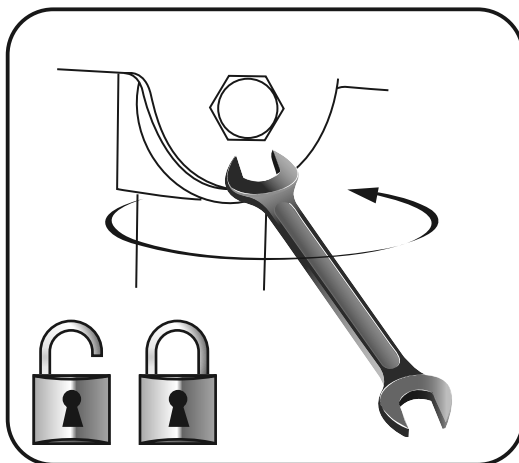
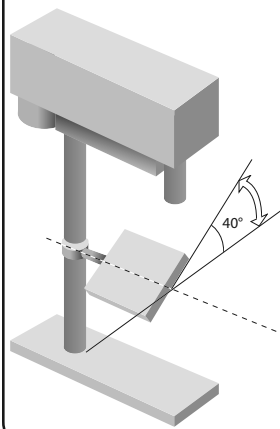

04

- (1) Tourner la molette jusqu'à la valeur de la profondeur désirée et verrouiller (2).
- (1) Draai de instelknop tot de waarde van de gewenste diepte en slot (2).
- (1) Gire el dial hasta que el valor de la profundidad y el bloqueo deseado (2).
- (1) Gire o botão até que o valor da profundidade e bloqueio desejado (2).
- (1) Girare la manopola fino a che il valore della profondità e di blocco desiderato (2).
- (1) Turn the knob until the value of the desired depth and lock (2).

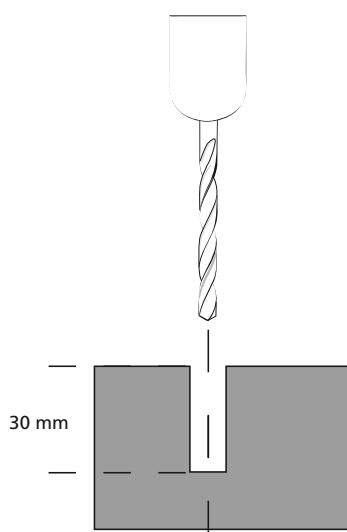
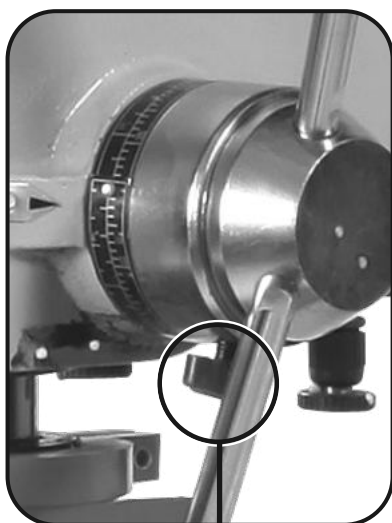

1

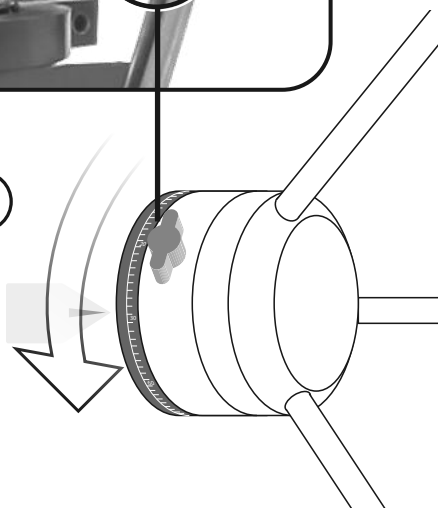

2

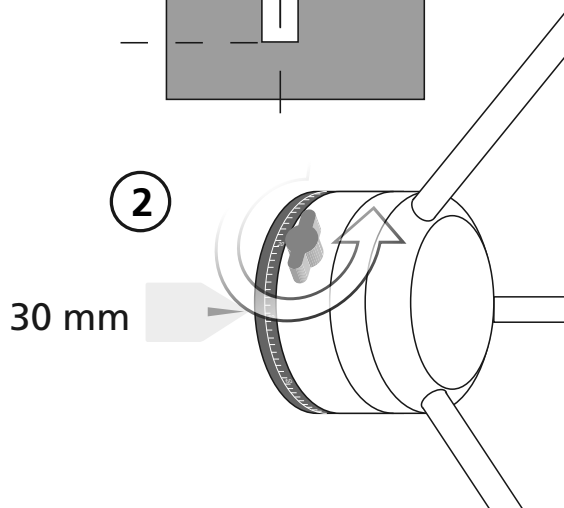

Changement des vitesses - Schakelen - Cambio de marchas - Mudança de velocidades - Cambiare marce - Changing gears

05

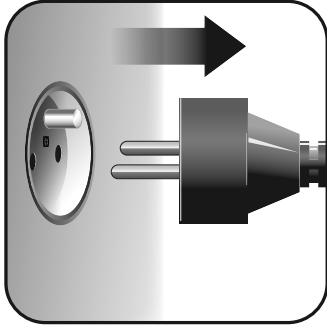

Assurez vous que la perceuse est immobilisée complètement avant de changer les vitesses.

- 1- Débrancher la perceuse
- 2- Avant la première utilisation, déverrouiller les 3 vis de serrage du moteur (a, b, c)
- 3- Tourner la molette située à l'arrière, derrière la poulie, de façon à faire avancer cette dernière et ainsi détendre la courroie.
- 4- Placer les courroies de façon à obtenir la vitesse désirée.
- 5- Replacer le moteur vers l'arrière de la perceuse en utilisant la molette
- 6- Resserrer les 3 vis de serrage et vérifier la tension des courroies. Des courroies trop tendues risquent de détériorer les poulies et les roulements.

Zorg ervoor dat de boor volledig geïmmobiliseerd voordat u snelheden.

- 1 - Trek de boor
- 2 - Voor het eerste gebruik, ontgrendelen de 3 schroeven op de motor
- 3 - Draai de knop op de achterkant, achter de poelie om zo de laatste bevorderen en daarmee maak de riem.
- 4 - Plaats de riem om de gewenste snelheid te verkrijgen.
- 5 - Vervang de motor aan de achterkant van de boor met de draaiknop
- 6 - Draai 3 schroeven voor de veiligheid en controleer de riemspanning. Riem te strak kan de katrollen en lagers beschadigen

Asegúrese de que el taladro está completamente inmovilizado antes de cambiar las velocidades.

- 1 - Desconecte el taladro
- 2 - Antes del primer uso, desbloquear los 3 tornillos en el motor
- 3 - Gire la perilla en la parte trasera, detrás de la polea con el fin de avanzar en este último y, por tanto aflojar el cinturón.
- 4 - Coloque el cinturón a fin de obtener la velocidad deseada.
- 5 - Colocar el motor en la parte trasera de la broca con el dial
- 6 - Apretar el tornillo 3 para la seguridad y comprobar la tensión de la correa. Cinturón demasiado apretada puede dañar las poleas y rodamientos

Certifique-se que a broca é completamente imobilizado antes de mudar de velocidades.

- 1 - Desligue a broca
- 2 - Antes da primeira utilização, desbloquear os 3 parafusos no motor
- 3 - Gire o botão na parte traseira, atrás da polia, de modo a promover o último e, assim, afrouxar o cinto.
- 4 - Colocar o cinto de modo a obter a velocidade desejada.
- 5 - Substituir o motor para a parte traseira da broca usando o mostrador
- 6 - Aperte 3 parafuso de segurança e verificar a tensão da correia. Correia muito apertada pode danificar as polias e rolamentos

Assicurarsi che il trapano è completamente immobilizzato prima di cambiare velocità.

- 1 - Scollegare il trapano
- 2 - Prima del primo utilizzo, sbloccare le 3 viti sul motore
- 3 - Ruotare la manopola posteriore, dietro la puleggia in modo da avanzare quest'ultimo e quindi allentare la cinghia.
- 4 - Posizionare la cintura in modo da ottenere la velocità desiderata.
- 5 - Sostituire il motore verso la parte posteriore del trapano utilizzando la manopola
- 6 - Serrare 3 vite per la sicurezza e controllare la tensione della cinghia. Cintura troppo stretto può danneggiare le pulegge e cuscinetti

Make sure the drill is completely immobilized before changing speeds.

- 1 - Unplug the drill
- 2 - Before first use, unlock the 3 screws on the motor
- 3 - Turn the knob on the rear, behind the pulley so as to advance the latter and thereby loosen the belt.
- 4 - Place the belt in order to obtain the desired speed.
- 5 - Replace the engine to the rear of the drill using the dial
- 6 - Tighten 3 screw and check the belt tension. Belt too tight can damage the pulleys and bearings

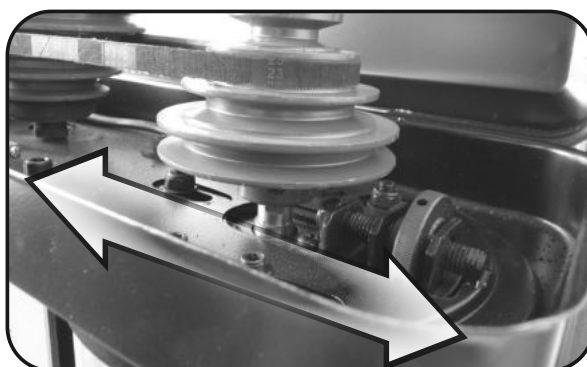
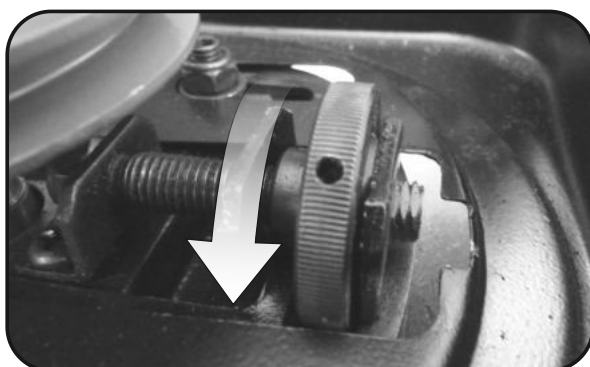
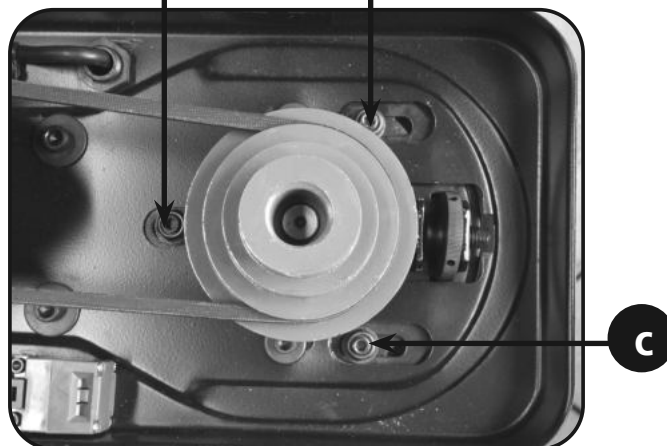
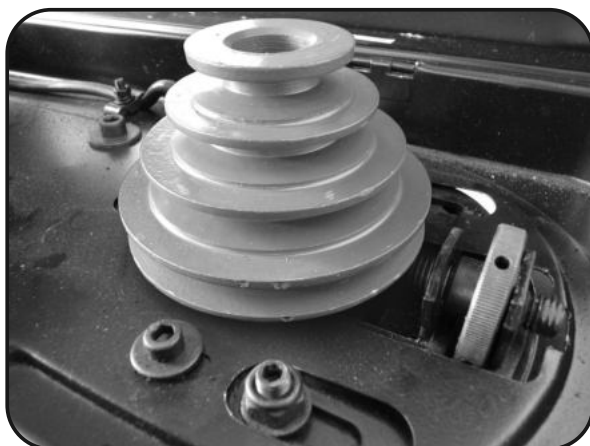



05



**A-4 180**

**C-3 650**

**A-3 270**

**B-2 720**

**B-4 310**

**E-3 1230**

**A-2 420**

**D-2 1320**

**C-4 430**

**C-1 1460**

**B-3 470**

**E-2 1880**

**D-4 580**

**D-1 1950**

**A-1 630**

**E-1 2770**

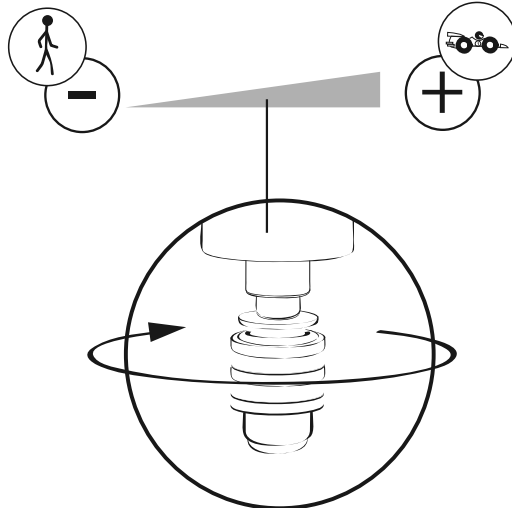
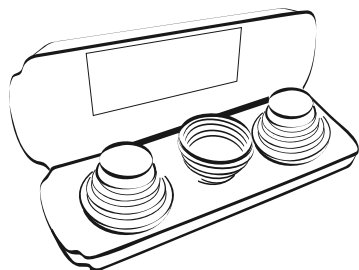



07

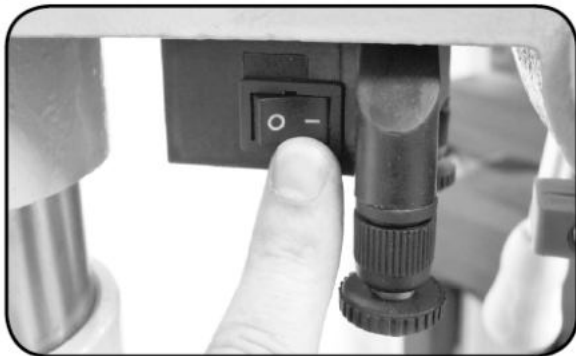

08

Utilisation de l'affichage digital - Met behulp van het digitale display - Usando la pantalla digital  
Usando o display digital - Utilizzando il display digitale - Using the digital display



## ON / OFF

**Allumage de l'écran**  
Start van het digitale display  
Inicio de la pantalla digital  
Início do display digital  
Inizio del display digitale  
Start of the digital display

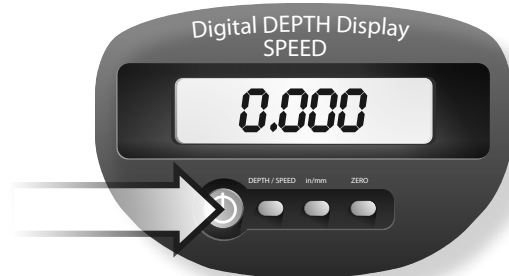

**Affichage des vitesses (RPM)**  
Weergave snelheid (RPM)  
Visualización de la velocidad (RPM)  
Velocidade display (RPM)  
Visualizza velocità (RPM)  
Display speed (RPM)



**Réappuyer sur le bouton pour :**  
Druk op de knop om:  
Pulse el botón de nuevo para:  
Pressione o botão novamente para:  
Premere nuovamente il pulsante per:  
Press the button again to:

**Affichage de la profondeur de perçage**  
Resultaat boordiepte  
Mostrando profundidad de perforación  
Mostrando profundidade de perfuração  
Mostrando profondità di foratura  
Showing drilling depth



**Affichage de la profondeur de perçage en millimètres**  
Resultaat boordiepte in millimeters  
Mostrando profundidad de perforación en milímetros  
Mostrando profundidade de perfuração em milímetros  
Mostrando profondità di foratura in millimetri  
Showing drilling depth in millimeters

**Réappuyer sur le bouton pour :**  
Druk op de knop om:  
Pulse el botón de nuevo para:  
Pressione o botão novamente para:  
Premere nuovamente il pulsante per:  
Press the button again to:

**Affichage de la profondeur de perçage en pouces**  
Resultaat boordiepte in inches  
Mostrando profundidad de perforación en pulgadas  
Mostrando profundidade de perfuração em polegadas  
Mostrando profondità di foratura in pollici  
Showing drilling depth in inches



# RPM :

Rotations Par Minute

Omwentelingen per minuut

Las rotaciones por minuto

Rotações por minuto

Rotazioni al minuto

Revolutions Per Minute

1 Inch = 25,4 mm

Remise a zéro (ZERO)

Scherm reset (ZERO)

Restablecimiento de la pantalla (ZERO)

Exibição de reposição (ZERO)

Reset del display (ZERO)

Display reset (ZERO)

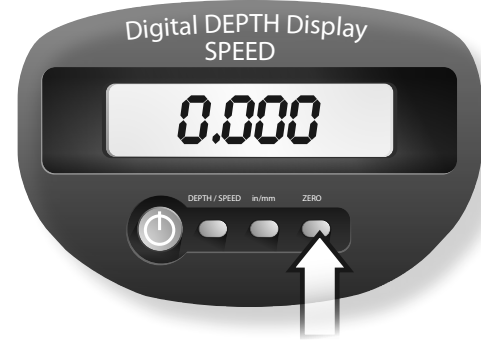

**IMPORTANT ! Ne pas travailler à main levée : toujours bloquer ou serrer la pièce sur la table et bloquer l'étau sur la table à l'aide des boulons**  
**BELANGRIJK! Werk niet de vrije hand: altijd op slot of klem het werkstuk op de tafel en hang de strop op de tafel met bouten**  
**¡IMPORTANTE! No trabajar a mano alzada: hay que bloquear o sujetar la pieza de trabajo sobre la mesa y colgar la soga en la mesa con los tornillos**  
**IMPORTANTE! Não trabalhe à mão livre: sempre bloquear ou prender a peça na mesa e pendurar a corda em cima da mesa com parafusos**  
**IMPORTANTE! Non lavorare a mano libera: sempre bloccare o bloccare il pezzo sul tavolo e appendere il cappio sul tavolo con bulloni**  
**IMPORTANT! Do not work freehand: always lock or clamp the workpiece on the table and hang the noose on the table with bolts**

10

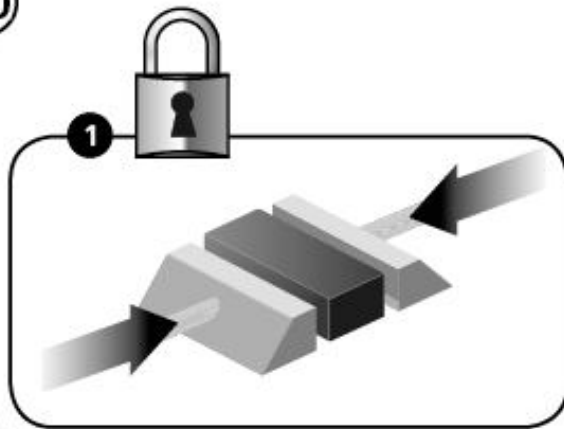

3

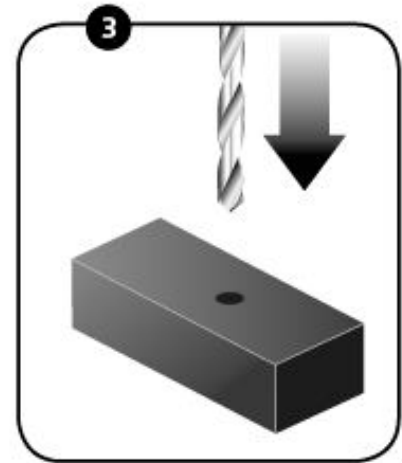
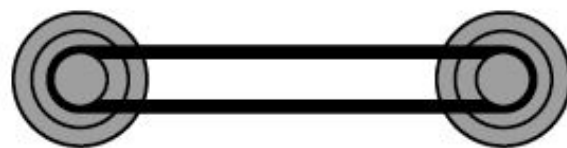
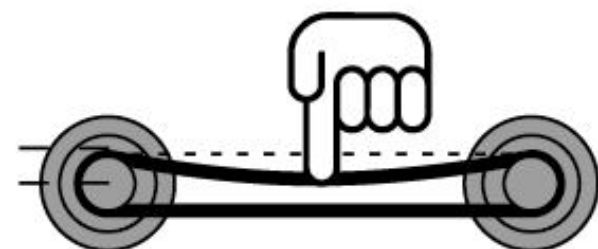

FIG. F

01



<10mm





04

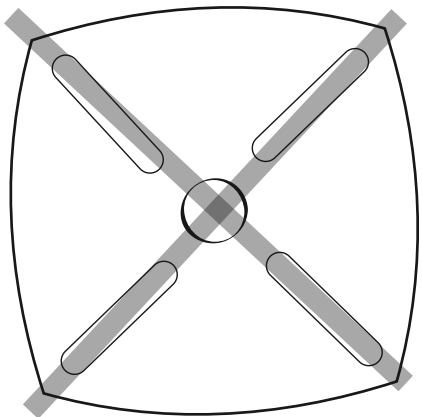
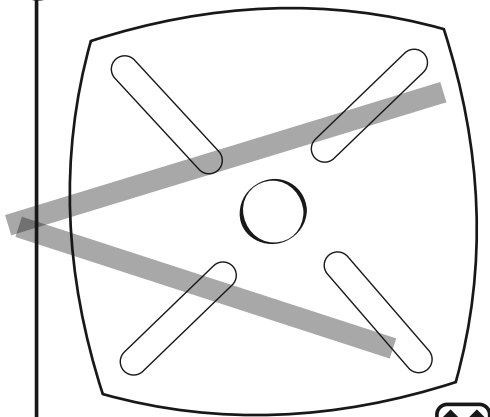

Régler le Laser en fonction de la hauteur de la table / la longueur du foret / la pièce à percer en tournant les molettes jusqu'à ce que le réglage soit adapté.

Pas de laser volgens de hoogte van de tabel/ de lengte van de boor/werkstuk door het draaien van de knoppen tot de aanpassing is aangepast.

Ajuste el láser según la altura de la tabla/ la longitud de la broca/pieza de soldar girando las perillas hasta que el ajuste se haya ajustado.

Ajuste o laser de acordo com a altura da tabela/o comprimento da broca/peça de trabalho girando os botões até que o ajuste seja ajustado.

Regolare il laser in base all'altezza della tavola/della lunghezza del trapano/pezzo ruotando le manopole fino a regolare la regolazione.

Adjust the Laser according to the height of the table/the length of the drill/workpiece by rotating the knobs until the adjustment is adjusted.

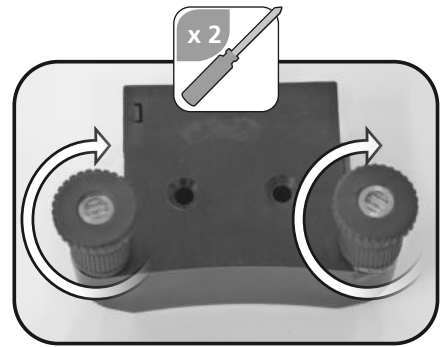



**Description et repérage des organes de la machine****FIG. A & B**

- 01 Interrupteur arrêt coup de poing
- 02 Table
- 03 Etau
- 04 Réglage table
- 05 Inclinaison table
- 06 Cabestan interchangeable
- 07 Tension courroie
- 08 -
- 09 Carter de mandrin
- 10 Capot poulie
- 11 Butée de profondeur
- 12 Affichage digital
- 13 Laser
- 14 -
- 15 -
- 16 -

**Contenu du carton****FIG. C****Assemblage de la machine****FIG. D**

- 01 Montage colonne
- 02 Montage crémaillère
- 03 Montage de la tête
- 04 Montage des piles
- 05 Fixation de la machine

**Fonctionnalité de la machine****FIG. E**

- 01 Mise en marche et arrêt
- 02 Montage-démontage des accessoires
- 03 Orientation de la table
- 04 Utilisation de la butée de profondeur
- 05 Comment changer de vitesse
- 06 -
- 07 Utilisation du laser
- 08 Utilisation de l'affichage digital
- 09 -
- 10 Réalisation d'un perçage

**Réglages de la machine****FIG. F**

- 01 Tension des courroies
- 02 -
- 03 -
- 04 Réglage du laser

**Remplacement des consommables****FIG. G**

- 01 Accessoires disponibles
- 02 -

**Entretien, recommandations et conseils**

- 01 L'utilisation d'accessoires adaptés et en bon état est garante d'un fonctionnement optimal.
- 02 Graissage de la broche
- 03 Pour éviter la rouille, graisser les parties métalliques usinées ( table, colonne, ... )
- 04 Vérifier l'état des courroies régulièrement
- 05 Lubrifier lors du perçage le foret avec un mélange d'huile soluble et d'eau
- 06 Adapter la vitesse de rotation du mandrin au diamètre du foret:
  - Petit diamètre = grande vitesse
  - Gros diamètre = petite vitesse

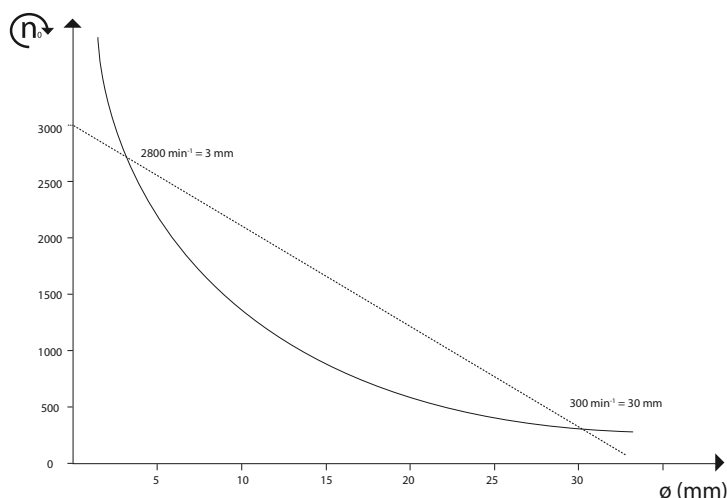

**Description and location of machine parts****FIG. A & B**

- 01 Safety switch
- 02 Table
- 03 Vice
- 04 Table adjustment
- 05 Table inclination
- 06 Capstan
- 07 Belt tension
- 08 -
- 09 Chuck guard
- 10 Pulley hood
- 11 Depth-stop
- 12 Digital display
- 13 Laser
- 14 -
- 15 -
- 16 -

**Contents of box****FIG. C****Assembling the machine****FIG. D**

- 01 Column assembly
- 02 Rack assembly
- 03 Head assembly
- 04 Assembly batteries
- 05 Securing the machine

**Functions of the machine****FIG. E**

- 01 Starting and stop
- 02 Assembly and dismantling of accessories
- 03 Table orientation
- 04 Use of butted of depth
- 05 How to change speed
- 06 -
- 07 Use of the laser
- 08 Use of the digital display
- 09 -
- 10 Drilling a hole

**Settings of the machine****FIG. F**

- 01 Belt tension
- 02 -
- 03 -
- 04 Adjustment of the laser

**Replacing consumables****FIG. G**

- 01 Accessories available
- 02 -

**Maintenance, recommendations and advice**

- 01 The use of suitable accessories in good condition will ensure the machine operates optimally
- 02 Spindle lubrication
- 03 To avoid rust, grease machined metal parts (table, column, etc.)
- 04 Check the condition of the belts regularly
- 05 Lubricate the bit when drilling with a mixture of soluble oil and water
- 06 Adapt the rotation speed of the chuck to the diameter of the drill:
  - Small diameter = high speed
  - Large diameter = low speed

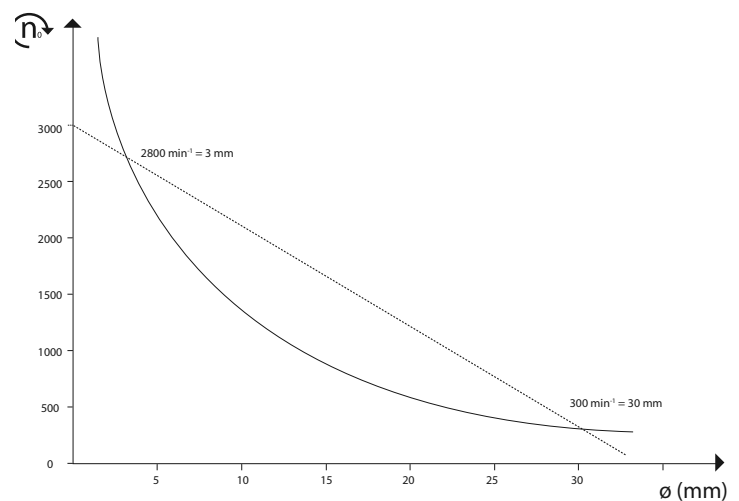

**Descripción y localización de los elementos de la máquina****FIG. A & B**

- 01 Interruptor de seguridad
- 02 Mesa
- 03 Torno
- 04 Regulación de la mesa
- 05 Inclinación de la mesa
- 06 Cabrestante
- 07 Tensión de la correa
- 08 -
- 09 Cáster del mandril
- 10 Tapa de la polea
- 11 Tope de profundidad
- 12 Visualización digital
- 13 Laser
- 14 -
- 15 -
- 16 -

**Contenido del cartón****FIG. C****Ensamblaje de la máquina****FIG. D**

- 01 Montaje de la columna
- 02 Montaje de la cremallera
- 03 Montaje del cabezal
- 04 Montaje de las pilas
- 05 Fijación de la máquina

**Funcionalidad de la máquina****FIG. E**

- 01 Puesta en marcha y paro
- 02 Montaje-desmontaje de los accesorios
- 03 Orientación de la mesa
- 04 Utilización del impulso de profundidad
- 05 Cómo cambiar de velocidad
- 06 -
- 07 Utilización del láser
- 08 Utilización de la visualización digital
- 09 -
- 10 Realización de un taladrado

**Ajustes de la máquina****FIG. F**

- 01 Tensión de las correas
- 02 -
- 03 -
- 04 Regulación del láser

**Cambio de los consumibles****FIG. G**

- 01 Accesorios disponibles
- 02 -

**Mantenimiento, recomendaciones y consejos**

- 01 La utilización de accesorios adecuados y en buen estado garantiza un funcionamiento óptimo
- 02 Engrase del husillo
- 03 Para evitar la oxidación, engrasar las partes metálicas mecanizadas (mesa, columna,...)
- 04 Controlar el estado de las correas con regularidad
- 05 Cuando se taladra lubricar la broca con una mezcla de aceite soluble y de agua
- 06 Cambie la velocidad de rotación del diámetro del mandril:
  - Diámetro pequeño = alta velocidad
  - Diámetro grande menor velocidad =

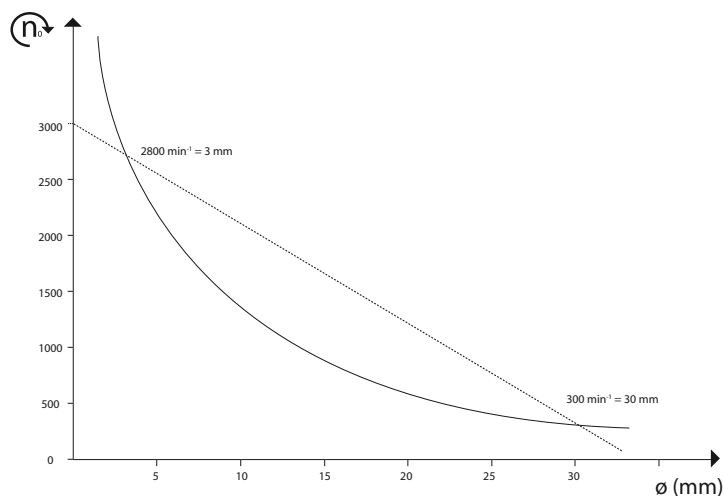

**Descrizione e localizzazione degli organi della macchina****FIG. A & B**

- 01 Interruttore di sicurezza
- 02 Tavolo
- 03 Morsetto
- 04 Regolazione del tavolo
- 05 Inclinazione del tavolo
- 06 Argano
- 07 Tensione della cinghia
- 08 -
- 09 Carter del mandrino
- 10 Cofano della puleggia
- 11 Finecorsa di profondità
- 12 Visualizzazione digitale
- 13 Laser
- 14 -
- 15 -
- 16 -

**Contenuto della scatola****FIG. C****Assemblaggio della macchina****FIG. D**

- 01 Montaggio della colonna
- 02 Montaggio cremagliera
- 03 Montaggio della testa
- 04 Assemblaggio delle pile
- 05 Fissa della macchina

**Funzionalità della macchina****FIG. E**

- 01 Messa in marcia e sentenza
- 02 Montaggio-smontaggio degli accessori
- 03 Orientazione del tavolo
- 04 BUtilizzo del paracolpi di profondità
- 05 Come cambiare la velocità
- 06 -
- 07 Utilizzazione del laser
- 08 Utilizzazione del visualizzazione digitale
- 09 -
- 10 -

**Regolazioni della macchina****FIG. F**

- 01 Tensione delle cinghie
- 02 -
- 03 -
- 04 Regolazione del laser

**Sostituzione dei pezzi di ricambio****FIG. G**

- 01 Accessori disponibili
- 02 -

**Manutenzione, raccomandazioni e consigli**

- 01 L'uso d'accessori adatti e buono stato è la garanzia di un funzionamento ottimale.
- 02 Lubrificazione del mandrino
- 03 Per evitare la ruggine, lubrificare le parte metalliche maniftture (tavola, colonna...)
- 04 Verificare lo stato delle cinghie regolarmente
- 05 Durante la perforazione, lubrificare la punta con una mescolanza d'olio solubile è d'acqua.
- 06 Far adattare la velocità della rotazione del mandrino al diametro della punta:
  - Piccolo diametro = grande velocità
  - Grosso diametro = Piccola velocità.

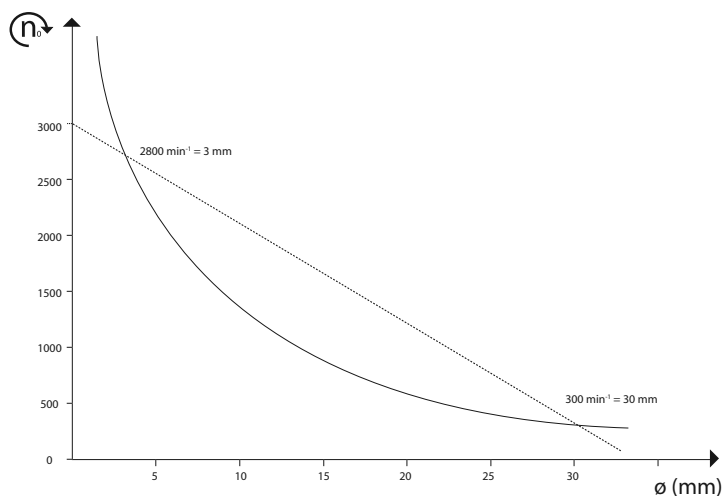

**Descrição e identificação dos órgãos da máquina****FIG. A & B**

- 01 Interruptor de segurança
- 02 Mesa
- 03 Torno
- 04 Ajuste da mesa
- 05 Inclinação da mesa
- 06 Cabrestante
- 07 Tensão da correia
- 08 -
- 09 Cárter do mandril
- 10 Capot da polie
- 11 Fim de curso de profundidade
- 12 Mostrador digital
- 13 Laser
- 14 -
- 15 -
- 16 -

**conteúdo da caixa****FIG. C****Montagem da máquina****FIG. D**

- 01 Montagem da coluna
- 02 Montagem da cremalheira
- 03 Montagem da cabeça
- 04 Montagem das pilhas
- 05 Machinebevestiging

**Funcionalidade da máquina****FIG. E**

- 01 Accionamento
- 02 Montagem / desmontagem dos acessórios
- 03 Orientação da mesa
- 04 Utilização do fim de curso de profundidade
- 05 Como mudar de velocidade
- 06 -
- 07 Acendimento do laser
- 08 Utilização da mostrador digital
- 09 -
- 10 Realização de furos

**Ajustes da máquina****FIG. F**

- 01 Tensão das correias
- 02 -
- 03 -
- 04 Ajuste da laser

**Substituição de consumíveis****FIG. G**

- 01 Acessórios disponíveis
- 02 -

**Manutenção preventiva, recomendações e conselhos**

- 01 A utilização de acessórios adaptados e em boas condições é a garantia de um funcionamento ideal
- 02 Lubrificação da broca
- 03 Para evitar a ferrugem, lubrificar as partes metálicas maquinadas (mesa, coluna, etc.)
- 04 Verificar o estado das correias regularmente
- 05 Durante a perfuração, lubrificar a broca com uma mistura de óleo solúvel e água
- 06 Altere a velocidade de rotação do mandril de diâmetro:
  - De pequeno diâmetro = alta velocidade
  - De grande diâmetro = baixa velocidade

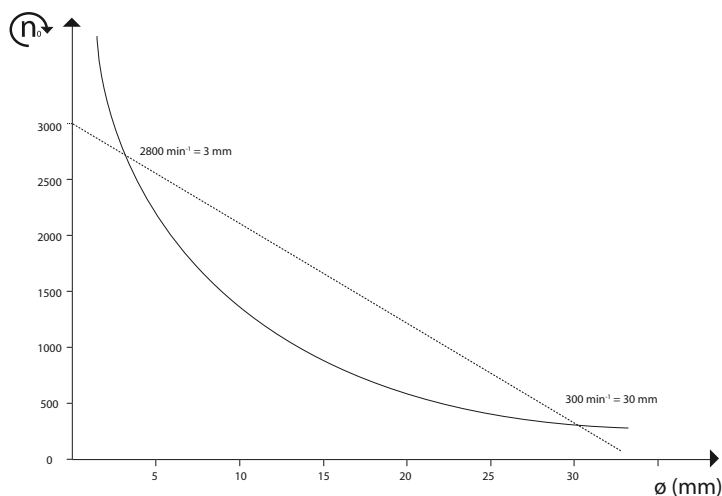

**Beschrijving en plaatsbepaling van de onderdelen van de machine****FIG. A & B**

- 01 Veiligheidsschakelaar
- 02 Tafel
- 03 Bankschroe
- 04 Tafelregeling
- 05 Tafelkanteling
- 06 Windas
- 07 Riemsparing
- 08 -
- 09 Klemhouder
- 10 Kap takel
- 11 Diepteanslag
- 12 Digitaal meten
- 13 Laser
- 14 -
- 15 -
- 16 -

**Inhoud van het karton****FIG. C****Assemblage van de machine****FIG. D**

- 01 Kolommontage
- 02 Hangijzermontage
- 03 Montage van de kop
- 04 Montage van de batterijenn
- 05 Machinebevestiging

**Functionaliteit van de machine****FIG. E**

- 01 Aanzetten
- 02 Montage-demontage van de toebehoren
- 03 Oriëntatie van de tafel
- 04 Gebruik van de Lengteaanslag
- 05 Hoe van versnelling wisselen
- 06 -
- 07 Aansteken van de laser
- 08 Aansteken van de digitaal meten
- 09 -
- 10 Boren

**Afstellingen van de machine****FIG. F**

- 01 Riemsparing
- 02 -
- 03 -
- 04 Aansteken van de laser

**Vervanging van de accessoires****FIG. G**

- 01 Beschikbare toebehoren
- 02 -

**Onderhoud, aanbevelingen en raadgevingen**

- 01 Het gebruik van de aangepaste accessoires in goede staat waarborgt een optimale werking
- 02 Smering van de frees
- 03 Om roest te voorkomen moet u de bewerkte metalen delen smeren (tafel, kolom, ...)
- 04 De toestand van de riemen regelmatig controleren
- 05 Voor het boren de boor insmeren met een mengsel van olie opgelost in water
- 06 Verander de snelheid van de rotatie van de boorkop met een diameter:
  - Met een kleine diameter = hoge snelheid
  - Grote diameter = lage snelheid

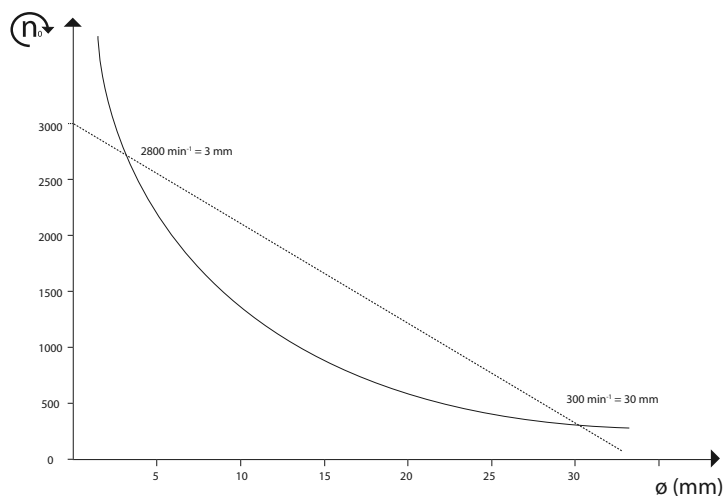



	TENSION ET FRÉQUENCE ASSIGNÉE:	230 V ~ 50 Hz
	AANGEWEZEN SPANNING EN FREQUENTIE:	
	TENSIÓN Y FRECUENCIA FIJADA:	
	TENSÃO E FREQUÊNCIA FIXA:	
	TENSIONE E FREQUENZA ASSEGNATA:	
NOMINAL FREQUENCY AND POWER:		

	PUISSANCE ASSIGNÉE:	550 W
	ONBELAST TOERENTAL:	
	POTENCIA FIJADA:	
	POTÊNCIA ASSINADA:	
	POTENZA ASSEGNATA:	
NOMINAL POWER:		

	VITESSE À VIDE:	180-2770 min <sup>-1</sup>   x16
	LEERLAUFDREHZAHL:	
	VELOCIDAD VACÍA:	
	VELOCIDADE NO VÁCUO:	
	VELOCITÀ A VUOTO:	
NO-LOAD SPEED:		

	LIRE LES INSTRUCTIONS AVANT USAGE :	X
	LEES VOOR HET GEBRUIK DE INSTRUCTIES :	
	LÉASE LAS INSTRUCCIONES ANTES DE USAR :	
	LER AS INSTRUÇÕES ANTES DA UTILIZAÇÃO :	
	LEGGERE LE ISTRUZIONI PRIMA DELL'USO :	
READ THE INSTRUCTIONS BEFORE USE :		

	POIDS :	45 kg
	GEWICHT :	
	PESO :	
	PESO :	
	PESO :	
WEIGHT :		

	CONFORMITÉ EUROPÉENNE :	X
	VOLDOET AAN DE EG-NORMEN :	
	CUMPLE CON LAS DIRECTIVAS CÉ :	
	CONFORME ÀS NORMAS CÉ :	
	CONFORME ALLE NORME CÉ :	
CONFORMS TO EC STANDARDS :		

	DANGER :	X
	GEVAAR :	
	PELIGRO :	
	PERIGO :	
	PERICOLO :	
DANGER :		

IP 20	X
-------	---

	PORTER DES LUNETTES DE SÉCURITÉ : PORTER UN MASQUE ANTI-POUSSIÈRE: PORTER UNE PROTECTION AUDITIVE:	X
	SCHUTZBRILLE TRAGEN : STAUBSCHUTZMASKE TRAGEN : GEHÖRSCHUTZ TRAGEN:	
	DRAAG EEN VEILIGHEIDSBRIL : DRAAG EEN STOFMASKER : DRAAG GEHOORBESCHERMERS:	
	LLEVAR PUESTAS GAFAS PROTECTORAS : LLEVAR PUESTA UNA CARETA DE PROTECCIÓN CONTRA EL POLVO : LLEVAR PUESTA UNA PROTECCIÓN AUDITIVA:	
	PORTARE DE GLI OCCHIALI DI SICUREZZA : INDOSSARE UNA MASCHERINA ANTI-POLVERE : PORTARE UNA PROTEZIONE UDITIVA:	
UTILIZAR ÓCULOS DE SEGURANÇA : UTILIZAR UMA MÁSCARA ANTI-POEIRA : UTILIZAR UMA PROTECÇÃO AUDITIVA:		
WEAR PROTECTIVE EYEWEAR : WEAR A DUST MASK : WEAR HEARING PROTECTIVE EQUIPMENT:		

	PORTER DES GANTS :	X
	DRAAG VEILIGHEIDSHANDSCHOENEN :	
	LLEVAR GUANTES DE PROTECCIÓN :	
	UTILIZAR LUVAS DE PROTECÇÃO :	
INDOSSARE I GUANTI DI PROTEZIONE :		
USE RUBBER GLOVES :		

	NIVEAU DE PRESSION ACOUSTIQUE :	75,2 dB (A)
	NIVEAU AKOESTISCHE DRUK :	
	NÍVEL DE PRESIÓN ACÚSTICA :	
	NÍVEL DE PRESSÃO ACÚSTICA :	
	LIVELLO DI PRESSIONE ACUSTICA :	
ACOUSTIC PRESSURE LEVEL :		

	NIVEAU DE PUISSANCE ACOUSTIQUE :	88,2 dB (A)
	NIVEAU AKOESTISCH VERMOGEN :	
	NÍVEL DE POTENCIA ACÚSTICA :	
	NÍVEL DE POTÊNCIA ACÚSTICA:	
	LIVELLO DI POTENZA ACUSTICA:	
ACOUSTIC POWER LEVEL :		

<b>NIVEAU SONORE D'EMISSION:</b>	<b>A</b>
<b>VIDE</b>	
Pression acoustique LpA poste opérateur	75,2 dB
Incertitude	3
Puissance acoustique LWA	88,2 dB
Incertitude	3

VALEURS DÉTERMINÉES SUIVANT LE CODE D'ESSAI DE L'ANNEXE B DE LA NORME EN 61029-1 AVEC EMPLOI DES NORMES DE BASE ISO 11201 ET ISO 3744.

LES NIVEAUX DE PRESSION ACOUSTIQUE OBTENUS IN SITU DÉPENDENT:

- DES NIVEAUX RÉELS DE LA MACHINE CONSIDÉRÉES, EN PRENANT EN COMPTE LES INCERTITUDES DÉCLARÉES.
- DU LOCAL ET DE L'INSTALLATION DE LA MACHINE. PRÉFÉREZ UNE PIÈCE DONT L'ACOUSTIQUE EST PLUS FEUTRÉE. ÉVITEZ LES PIÈCES VIDE À GRANDE RÉSONANCE. PLACEZ-VOUS AUPRÈS D'UNE FENÊTRE LE CAS ÉCHÉANT.
- DES OUTILS MONTÉS, DES PIÈCES TRAVAILLÉES, DES RÉGLAGES CHOISIS,...





	RAYONNEMENT LASER - NE PAS REGARDER DANS LE FAISCEAU - APPAREIL À LASER DE CLASSE 2	X
	LASERSTRALING - KIK NIET THE BEAM - POWER LASER KLASSE 2	
	ADIACIÓN LÁSER - NO MIRE EL RAYO - CLASE LASER POWER 2	
	RADIAÇÃO LASER - NÃO OLHE O RAIÃO - CLASSE POTÊNCIA DO LASER 2	
	RADIAZIONE LASER - NON FISSARE IL RAGGIO - CLASSE LASER POWER 2	
	LASER RADIANCE : DO NOT LOOK INSIDE THE BEAM CLASS 2 LASER	

	SOUMIS À RECYCLAGE :	X
	NIET WEGWERPEN :	
	SOTTOPOSTI A RICICLAGGIO :	
	SUJEITOS À RECICLAGEM :	
	SOTTOPOSTI A RICICLAGGIO :	
	SUBJECTED TO RECYCLING :	

**FR-RECYCLAGE DES DÉCHETS:**

LES OUTILS, ACCESSOIRES ET LEUR EMBALLAGES DOIVENT SUIVRE UNE VOIE DE RECYCLAGE ADAPTEE. CONFORMEMENT AUX DIRECTIVES EUROPÉENNE 2012/19/UE ET 2006/66/CE, LES COMPOSANTS D'UN PRODUIT DOIVENT ÊTRE SÉPARÉS, COLLECTÉS, RECYCLÉS OU ÉLIMINÉS EN CONFORMITÉ AVEC LES RÉGLEMENTATIONS ENVIRONNEMENTALES EN VIGUEUR. LES APPAREILS, BATTERIES, PILES, HUILES, EMBALLAGES DEVRONT ÊTRE DÉPOSÉS DANS LES SYSTÈMES D'ÉLIMINATION DES DÉCHETS SPÉCIAUX TELS QUE DÉCHETTERIES. RENSEIGNEZ VOUS AUPRÈS DE VOTRE COMMUNE POUR CONNAÎTRE L'ORGANISME LE PLUS PROCHE À MÊME DE RETRAITER OU DE COLLECTER CES DÉCHETS.

**NL-AFVAL RECYCLING:**

GEREEDSCHAP, ACCESSOIRES EN VERPAKKINGEN MOETEN VOLGEN EEN PAD GESCHIKT IS VOOR RECYCLING. VOLGENS DE EUROPESE RICHTLIJNEN 2012/19/UE EN 2006/66/CE, DE COMPONENTEN VAN EEN PRODUCT MOET WORDEN GESCHIEDEN, VERZAMELD, GERECYCLEERD OF VERWIJDERD IN OVEREENSTEMMING MET DE MILIEUVOORSCHRIFTEN. APPARATEN, BATTERIJEN, OLIE, MOET DE VERPAKKING WORDEN GEDEPONEERD IN DE AFVALVERWERKING AFVAL, ZOALS STORTPLAATSEN. NEEM CONTACT OP MET UW GEMEENTE NAAR DE DICHTSTBIJZIJNDE AGENTSCHAP KUNNEN HERHALEN OF HET VERZAMELEN VAN DEZE AFVALSTOFFEN TE VINDEN.

**ES-RECIKLADO DE LOS RESIDUOS:**

LAS HERRAMIENTAS, LOS ACCESORIOS Y LOS ENVASES TIENEN QUE SEGUIR LA VÍA DE RECICLAJE ADECUADA. EN VIRTUD DE LAS DIRECTIVAS EUROPEAS 2012/19/UE Y 2006/66/CE, LOS COMPONENTES DE UN PRODUCTO DEBEN SEPARARSE, RECOGERSE, RECICLARSE O ELIMINARSE DE ACUERDO CON LAS REGLAMENTACIONES MEDIOAMBIENTALES VIGENTES. LOS APARATOS, BATERÍAS, PILAS, ACEITES, ENVASES DEBERÁN LLEVARSE A LOS CENTROS DE ELIMINACIÓN DE RESIDUOS ESPECIALES TALES COMO LOS ECOPARQUES. PEDIR INFORMACIÓN AL MUNICIPIO PAR CONOCER EL CENTRO MÁS CERCANO APTO PARA RECICLAR O RECOGER DICHOS RESIDUOS.

**PT-RECICLAGEM DO LIXO:**

AS FERRAMENTAS, ACESSÓRIOS E SUAS EMBALAGENS DEVEM SEGUIR UM CANAL DE RECICLAGEM ADAPTADO. CONFORMEMENTE ÀS DIRETIVAS EUROPEIAS 2012/19/UE E 2006/66/CE, OS COMPONENTES DE UM PRODUTO DEVEM SER SEPARADOS, RECOLHIDOS, RECICLADOS OU ELIMINADOS DE ACORDO COM AS REGULAMENTAÇÕES AMBIENTAIS EM VIGOR. OS APARELHOS, BATERIAS, PILHAS, ÓLEOS E EMBALAGENS DEVERÃO SER DEPOSITADOS NOS SISTEMAS DE ELIMINAÇÃO DE DETRITOS ESPECIAIS, TAIS COMO UNIDADES DE TRIAGEM DE DETRITOS. INFORMAR-SE JUNTO AO SEU CONCELHO MUNICIPAL PARA CONHECER O ÓRGÃO MAIS PRÓXIMO HABILITADO A EVACUAR OU RECOLHER ESTES DETRITOS.

**IT-RICICLAGGIO DEI RI\_LUTI:**

GLI APPARECCHI, I LORO ACCESSORI ED IMBALLAGGI DEVONO ESSERE SOTTOPOSTI AD UN PROCESSO DI RICICLAGGIO APPROPRIATO. IN CONFORMITÀ CON LE DIRETTIVE EUROPEE 2012/19/UE E 2006/66/CE, I COMPONENTI DI UN PRODOTTO DEVONO ESSERE SEPARATI, RACCOLTI, RICICLATI O SMALTITI IN CONFORMITÀ CON LE NORMATIVE AMBIENTALI IN VIGORE. GLI APPARECCHI, LE BATTERIE, LE PILE, GLI OLI, GLI IMBALLAGGI DOVRANNO ESSERE CONFERITI NEI SISTEMI DI SMALTIMENTO DEI RI\_LUTI SPECIALI COME LE ISOLE ECOLOGICHE. INFORMARSI PRESSO IL PROPRIO COMUNE PER SAPERE QUAL È L'ENTE PIÙ VICINO IN GRADO DI FARE IL TRATTAMENTO O LA RACCOLTA DIFFERENZIATA DI QUESTI RI\_LUTI

**EN-WASTE RECYCLING:**

THE TOOLS, ACCESSORIES AND THEIR PACKAGING MUST USE AN APPROPRIATE RECYCLING CHANNEL. IN COMPLIANCE WITH EUROPEAN DIRECTIVES 2012/19/UE AND 2006/66/CE, A PRODUCT'S COMPONENTS MUST BE SEPARATED, COLLECTED, RECYCLED OR ELIMINATED IN ACCORDANCE WITH THE ENVIRONMENTAL REGULATIONS IN FORCE. THE APPLIANCE, BATTERIES, OILS AND PACKAGING MUST BE DEPOSITED IN THE SPECIAL WASTE ELIMINATION SYSTEMS SUCH AS THE WASTE COLLECTION CENTRES. ASK YOUR COMMUNE FOR INFORMATION ON THE NEAREST ORGANISATION IN A POSITION TO REPROCESS OR COLLECT THIS WASTE





# EnergyDrill-16LBE

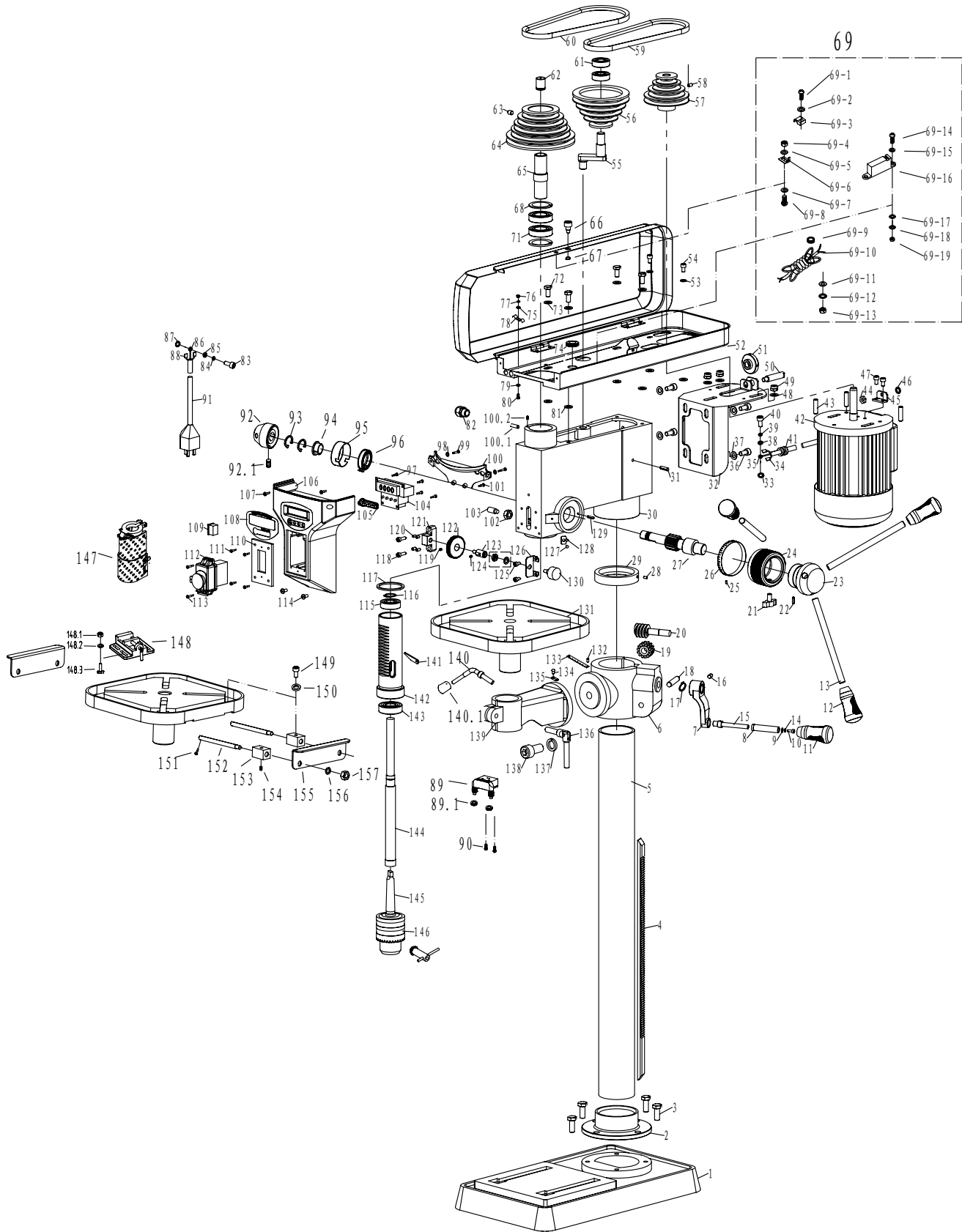

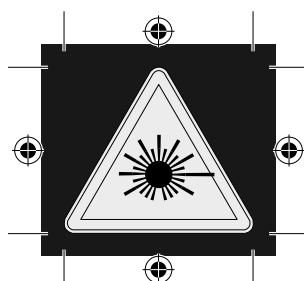
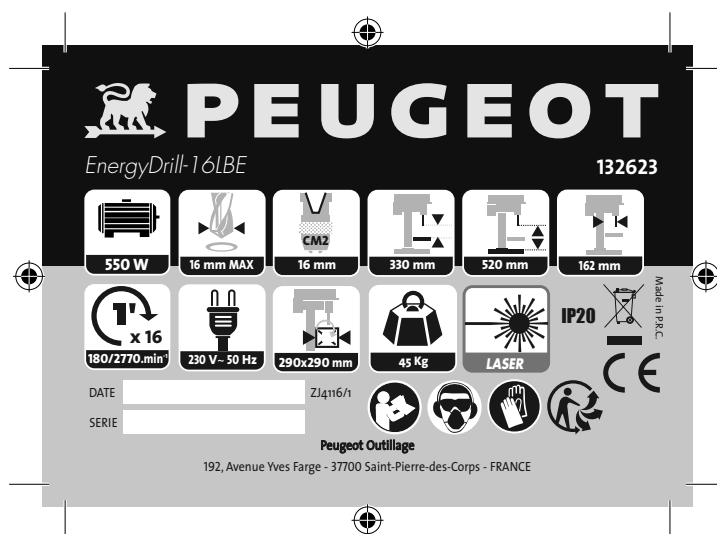



# PEUGEOT

DECLARATION CE DE CONFORMITE  
DECLARACION DE CONFORMIDAD  
DICHIARAZIONE DI CONFORMITA

VERKLARING VAN OVEREENSTEMMING  
DECLARAÇÃO DE CONFORMIDADE  
DECLARATION OF CE CONFORMITY

Le soussigné,  
Ondergetekende,  
El suscrito,  
O abaixo assinado,  
Il sottoscritto,  
The undersigned,

## PEUGEOT OUTILLAGE

192, Avenue Yves Farge - 37700 St. Pierre-des-Corps - FRANCE  
Tél. : 02 36 16 71 46 - Fax : 02 36 16 71 40

Déclare par la présente que,  
Verklaart hiermede dat,  
Declara por la presente, que,  
Declara pela presente que,  
Dichiare che,  
Declares that,

### CODE

PEUGEOT / 132623 / EnergyDrill-16LBE / ZJ4116/1

Perceuse colonne / Drill press / Kolomboormachine / Taladro a columna / Furador a colonna / Trapano a colonna

Est conforme et satisfait aux normes CE:  
In overeenstemming is met en Voldoet aan EG richtlijnen:  
Cumple con la directivas de la CE:  
Respeita e está em conformidade com as normas CE:  
È conforme alle direttive CEE:  
Complies with the EEC standards:

2006/42/EC, 2014/30/EU, 2011/65/EU 2015/863/EU

EN 55014-1:2017  
EN 55014-2:2015  
EN 61000-3-2:2014  
EN 61000-3-3:2013

EN 61029-1:2009/A11:2010

Personne autorisée à  
constituer le dossier technique :  
Christophe HUREL



Christophe HUREL,  
Président Directeur Général  
04/03/2020  
Fait à Saint Pierre-des-Corps



# PEUGEOT

## BON DE GARANTIE

### 1 - Objet de la garantie :

La garantie porte exclusivement sur les vices de fabrication ou les vices de matières. Elle nous oblige à l'échange ou à la réparation des pièces reconnues hors d'usage.

### 2 - Durée de la garantie :

La garantie est de 24 mois à dater de la livraison du matériel à l'utilisateur (facture ou ticket de caisse à fournir).

Les échanges ou réparations faites au titre de la garantie ne peuvent avoir pour effet de prolonger celle-ci.

Les frais de port ALLER sont à la charge de l'utilisateur.

### 3 - Réserves :

La garantie ne s'applique en aucun cas aux réparations effectuées en dehors de nos réparateurs agréés.

En aucun cas, durant la période de garantie, le matériel ne devra être démonté.

## GARANTIEKAART

### 1 - Doel van de garantie:

De garantie heeft uitsluitend betrekking op fabricagefouten of gebreken in materialen. Het dwingt ons om uit te wisselen of reparatie van erkende onbruikbare onderdelen.

### 2 - Duur van de garantie:

De garantie bedraagt 24 maanden vanaf de levering van apparatuur voor de gebruiker (factuur of kassabon te verstrekken).

De uitwisseling of reparaties onder garantie niet te verlengen.

GO verzendkosten zijn voor rekening van de gebruiker.

### 3 - Reserves:

De garantie geldt niet in alle reparaties die buiten onze goedgekeurde reparateurs.

In ieder geval gedurende de garantie, moet het materiaal worden verwijderd.

## TARJETA DE GARANTÍA

### 1 - Objeto de la garantía:

La garantía sólo se referirá a los defectos de fabricación o defectos en los materiales. Nos obliga a cambiar o reparación de las piezas fuera de servicio reconocido.

### 2 - Duración de la garantía:

La garantía es de 24 meses a partir de la entrega de equipos para el usuario (factura o recibo que se den).

Los intercambios o reparaciones bajo garantía no tendrá que prolongarse.

GO gastos de envío correrán a cargo del usuario.

### 3 - Reservas:

La garantía no se aplica en todas las reparaciones realizadas fuera de nuestros talleres de reparación autorizados.

En cualquier caso, durante el periodo de garantía, el material debe ser removido.

## CARTÃO DE GARANTIA

### 1 - Finalidade da garantia:

A garantia só relacionar com defeitos de fabricação ou defeitos em materiais.

Ela nos obriga a troca ou reparo de peças inservíveis reconhecidos.

### 2 - Duração da Garantia:

A garantia é de 24 meses a partir da entrega de equipamentos para o usuário (factura ou recibo a ser fornecido).

Trocas ou reparos sob a garantia não terá que prorrogá-la.

GO porte serão custeadas pelo usuário.

### 3 - Reservas:

A garantia não se aplica a quaisquer reparos feitos fora das nossas oficinas aprovadas.

Em qualquer caso, durante o período de garantia, o material deve ser removido.

## GARANZIA

### 1 - Oggetto della garanzia:

La garanzia si riferisce esclusivamente alla difetti di fabbricazione o difetti nei materiali.

Ci costringe a scambio o la riparazione di parti inutilizzabili riconosciuti.

### 2 - Durata della garanzia:

La garanzia è di 24 mesi dalla consegna delle attrezzature per l'utente (fattura o ricevuta da fornire).

Scambi o riparazioni in garanzia non sarà necessario prolungarla.

GO spese di spedizione sono a carico dell'utente.

### 3 - Riserve:

La garanzia non si applica in tutte le riparazioni effettuate al di fuori dei nostri riparatori autorizzati.

In ogni caso, durante il periodo di garanzia, il materiale deve essere rimosso.

## WARRANTY

### 1 - Scope of the warranty :

The warranty shall only apply to manufacturing defects or material defects.

We are obliged to exchange or repair parts that are identified as being unusable

### 2 - Lifetime warranty :

The warranty shall be valid for 24 months from the delivery date of the equipment to the user (invoice or till receipt must be provided).

Exchanges or repairs carried out under the warranty shall not extend the original warranty period.

The user shall be responsible for original shipping charges.

### 3 - Reservations :

The warranty shall not under any circumstances cover repairs carried out by a non-authorized repairer.

The equipment should not be dismantled under any circumstances during the warranty period.

DATE D'ACHAT	RÉFÉRENCE MACHINE	CACHET DU DISTRIBUTEUR
DATUM VAN AANKOOP	HOMING	DEALER STEMPEL
FECHA DE COMPRA	HOMING	COMERCIANTE DE SELLOS
DATA DA COMPRA	HOMING	SELO REVENDEDOR
DATA DI ACQUISTO	HOMING	TIMBRO DEL RIVENDITORE
PURCHASE DATE	MACHINE CODE	DISTRIBUTOR'S STAMP

## SERVICE APRÈS VENTE - AFTER SALE SERVICE

Peugeot Outillage - 192, Avenue Yves Farge - 37700 St. Pierre-des-Corps - FRANCE - Tél. : 02 36 16 71 44 - Fax : 02 36 16 71 40